

CONFERENCE
Price and Specification Guide
USA

vizient[™]



krug

Advancing Design Through Innovation

TABLE OF CONTENTS

PRICING & SPECIFICATIONS

126 Revo

General Information

349 Terms & Conditions

349 Warranty

351 *KrugExpress* Program

352 Wood Finishes

352 Laminate Program

353 Solid Surface

REVO | TABLE OF CONTENTS

REVO

125	Environmental Summary
126	Features & Options
130	Power Options
136	Seating Capacities
137	Example Configurations
138	Tables Fixed C & T Base
142	Nesting Tables C & T Base
145	Connecting Tops
146	Rectangular Folding Tables C & T Base
147	Modesty Panels
153	Power Features & Options

LEED CERTIFICATION



MATERIAL CONTENT:

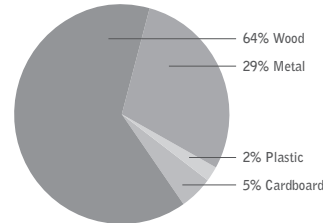

PRE-CONSUMER
RECYCLED CONTENT - 77%

POST-CONSUMER
RECYCLED CONTENT - 9%

		CONTRIBUTES To
Credit 2.1 - 2.2	Construction Waste Management	1-2 point(s)
Credit 3.3	Resource Reuse	1 point
Credit 4.1	Recycled Content	1 point
Credit 4.2	Recycled Content	1 point
Credit 4.5	Low Emitting Materials, (MUST BE REQUESTED) Composite Wood & Laminate Adhesives	1 point
Credit 5.1	Regional Materials*	1 point
Credit 6	Rapidly Renewable Materials (MUST BE REQUESTED)	1 point
Credit 7	Certified Wood (MUST BE REQUESTED)	1 point

*This credit is only applicable if in total 20% of the combined value of the procurement of construction materials and in the furniture are manufactured within a radius of 500 miles. This credit will apply if the installation of the finished product occurs within 500 miles of Kitchener, Ontario.



level® CERTIFICATION

BIFMA's e3 Furniture Sustainability Standard is a voluntary, multi-attribute standard that measures the degree of sustainability of furniture. This standard evaluates product and company environmental attributes and compliance systems in a wide range of elements which include Materials, Energy & Atmosphere, Human & Ecosystem Health and Social Responsibility. Revo products have earned level®, BIFMA's sustainability certification program for furniture, certification through third-party verification against the e3 standard. All Revo products can be supplied with level® certification. In order to accomplish this, the product must also be ordered with the air-emissions-certification option. Contact customer service for information and upcharges.



FSC
www.fsc.org
FSC® C021899

the mark of responsible forestry

AIR-EMISSIONS

All Revo products can be supplied with air-emissions-certified materials. Contact customer service for information and upcharges.

FSC®

In 2005, Krug received Forest Stewardship Council® (FSC®) Chain-of-Custody certification for our manufacturing facilities. The FSC® Chain-of-Custody tracks certified wood from seedling to final sale. It signifies that the growth, harvesting and production of goods are entirely achieved through responsible forestry, which guarantees a healthy supply of forest resources for generations to come. Revo and other Krug products can be specified with one of two types of FSC® Certification: (a) FSC®-certified (which includes FSC®-certified lumber, veneer and substrate material) (b) FSC®-mix certified (which includes substrate material only, and is a lower cost option certification) Contact customer service for further information, pricing and lead times.



In addition, architects, designers, and building professionals can specify FSC®-certified products in order to achieve a point from the U.S. Green Building Council's Leadership in Energy and Environmental Design (LEED) Rating System.

REVO | FEATURES & OPTIONS

TRAINING TABLE TOP SHAPES

Revo Training are available in 5 table top shapes.

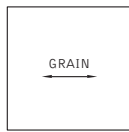

Square

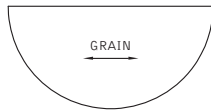

Half Round

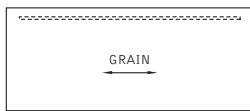

Rectangular

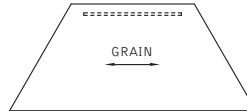

Trapezoid

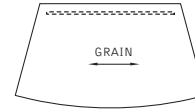

Arched Trapezoid

Dotted line depicts which side a modesty panel is available on. 1/2 Round and Square tops not available with modesty panels. Grommets, Surface Modules, PowerPorts and Ports when specified are positioned on the same side as the modesty panel.

WORKSURFACES

Worksurfaces with Knife (K) edge profile - Tops are 1 1/8" thick veneered, laminated - 45 lb. fibreboard MDF core and backer material.

Worksurfaces with T-Edge profile - Tops are 1 1/8" thick veneered, laminated -42 lbs. particleboard core with backer material.

Worksurfaces with D-Edge profile - Tops are 1 1/8" thick veneered, laminated -42 lbs. particleboard core with backer material.

All worksurfaces have a profiled edges on all sides. Corner Connecting tops have a profile on the curved edge only.

GRAIN DIRECTION - WOOD VENEER AND WOOD GRAIN LAMINATE

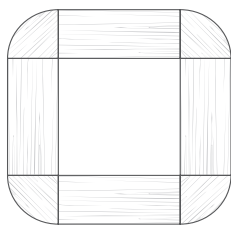

Please note: On Revo corner CONNECTOR TOPS, the grain runs on a 45° angle. For all other Revo Training tables, the grain runs lengthwise. For wood modesty panels the grain runs vertically. For laminate modesty panels, the grain runs horizontally.

EDGE OPTIONS – TRAINING TABLES

Revo training product offers 3 edge profiles.

D-Edge

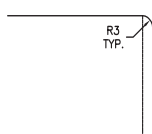

T-Edge

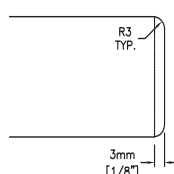

“D” edge profile and “T” edge profile are available on Wood and Laminate worksurfaces.

Knife Edge

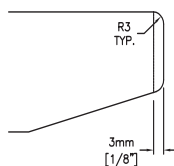

Knife Edge is optional on Wood and Laminate worksurfaces for a upcharge of **\$153 list** per table.

WOOD FINISH

A five step catalyzed varnish finish that when dry has a sheen value of 32° is applied to all Revo Training table tops.

METAL FINISH

Revo components have a powder coated Silver Metallic finish.

LEGS

Revo “T” and “C” style legs are available in fixed, folding and nesting versions. All legs are available with casters or glides. Revo legs with casters come with a 2” caster in Silver Metallic finish. They have the ability to lock with a foot release lever located at the base of the wheel. Revo legs with glides have 1 1/4” of height adjustment, longer glides are available upon request for very uneven floors. Revo legs allow for cables to be channeled through the leg and concealed with a snap-on cover which allows cord access to the top and bottom when required.

MODESTY PANELS

Revo modesty panels are available in wood, laminate and aluminum in both fixed and flip versions. Fixed modesty panels are available with no cable management trough, with cable management trough or cable management for power and data. The flip version is equipped for power and data with access from either side.

GANGING BRACKETS

A set of ganging brackets are recommended when 2 or more tables are being joined to one another. These ganging brackets should be ordered along with the tables as a separate line item on the order. All tables come pre-drilled for ganging capabilities. Please note corner connector tops are supplied with an alternative mounting plate. The Ganging Brackets are used to prevent separation of the tables when configured in a layout.

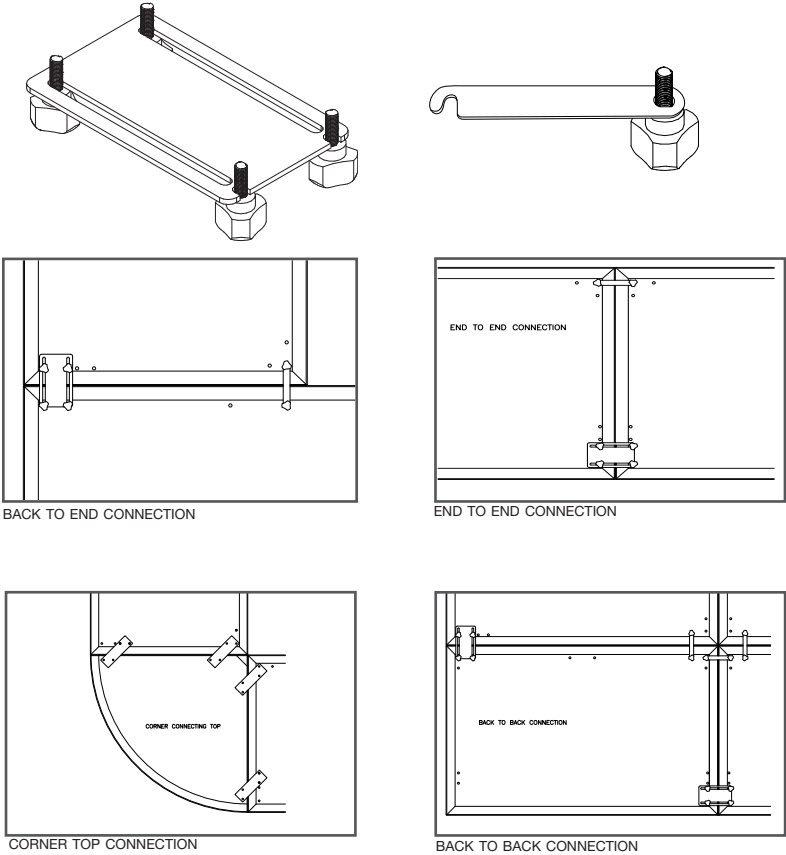

SELF STORING

The Ganging Brackets can be neatly tucked underneath the table when not being used to join to another table. This allows the Revo Training Tables to be easily reconfigured when wanting to add or subtract tables from existing configurations.

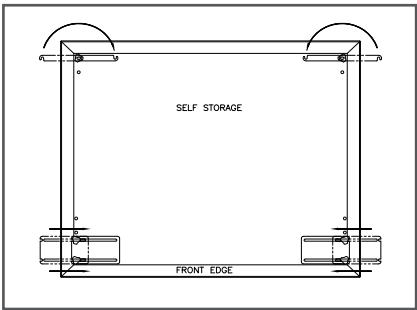

PACKAGING

Revo packaging features recycled and recyclable cardboard and bubble wrap. The product is shipped as separate components. Bases and modesty panels have to be attached to table top surface after delivery.

REVO | FEATURES & OPTIONS

REVO TRAINING BASES

All Revo Training C bases are available in 16" and 20" widths, with standard (W1) and high capacity (W2) cable managers. All Revo Training T bases are available in 20" width, with standard (W1) and high capacity (W2) cable managers.

BASE SIZES

16" C Bases are used on Revo Training Tables that are 20" in depth.

20" C Bases are used on Revo Training Tables that are 24" and 30" in depth.

20" T Bases are used on Revo Training Tables that are 24", 30" and 36" in depth.

Fixed T Base

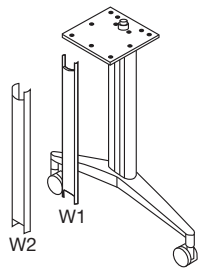

With Casters

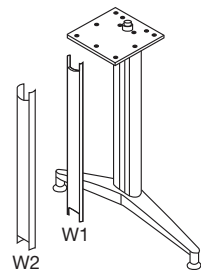

With Glides

Fixed C Base

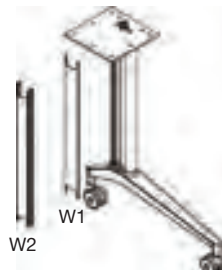

With Casters

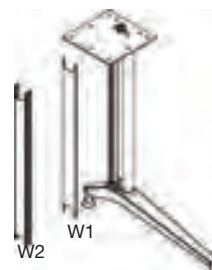

With Glides

Folding T Base



With Casters



With Glides

Folding C Base

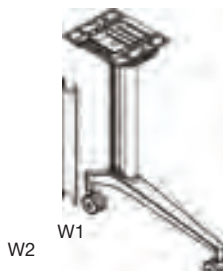

With Casters



With Glides

Nesting T Base

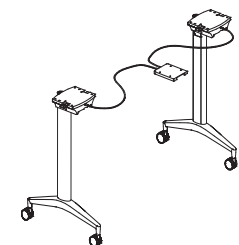

With Casters

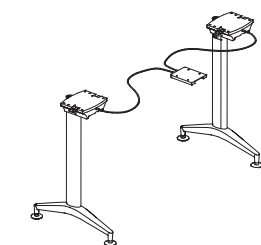

With Glides

Nesting C Base

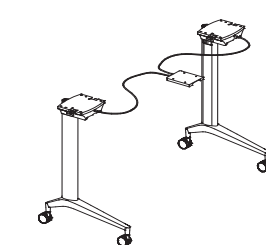

With Casters

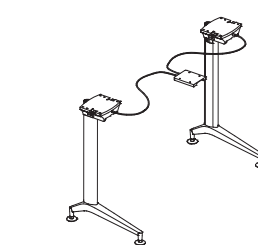

With Glides

REVO TRAINING | FEATURES & OPTIONS

REVO NESTING TABLES

With innovative design and clever construction, the Revo Nesting table is an ideal solution for training rooms, classrooms or meeting rooms. A simple and easy to operate one handed release handle allows the table top to rotate downwards 90 degrees for ease of storage or quick room configuration. In addition, the wheeled legs rotate 20 degrees for compact nested storage, resulting in an efficient use of space.

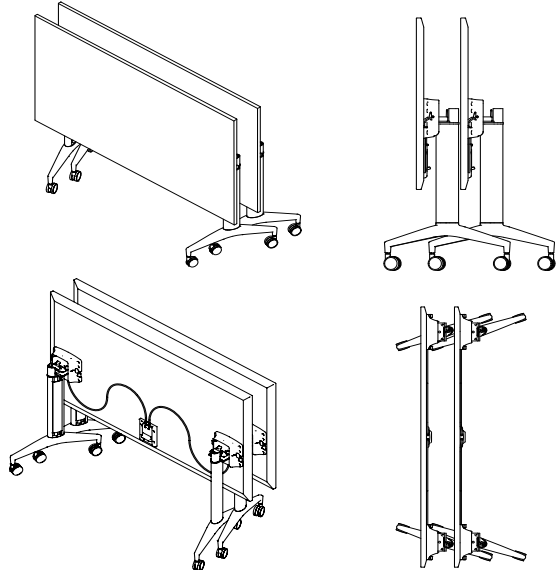

Nested Table Dimensions:

- 20" D table = 16 1/8"
- 24" D table = 19 7/8"
- 30" D table = 19 7/8"
- 36" D table = 32 1/8"

Add 7.5"D for each additional nested tables or add 12" if modesty panels are attached.

For Example: A 20" D table in a nested position is 16 1/8" D. Add 9 additional nesting tables (9 x 7.5"=67.5"D). Therefore, the depth requirement for nested tables is 83.75"D.

Total space required to nest 10 table without modesty panels is 83.75" x the length of the table.

Table Height of nested tables:

24" deep - T Base	41.75"	20" deep - C Base	37.25"
30" deep - T Base	44.75"	24" deep - C Base	37.25"
36" deep - T Base	47.5"	30" deep - C Base	40.25"
36" deep - T Base	47.5"		

REVO FOLDING TABLES

The Revo Folding Legs features our easy to use release lever that when activated retracts the legs parallel to be underside of the tabletop, allowing tables to be stacked vertically or horizontally. This feature can be used anywhere but is particularly beneficial in settings which need to be reconfigured quickly or frequently. The flattened table maximizes storage space. The optional storage cart, which holds up to 5 tables vertically, makes movement of the folded tables safe and easy. Folding tables cannot accommodate powerports or surface modules.

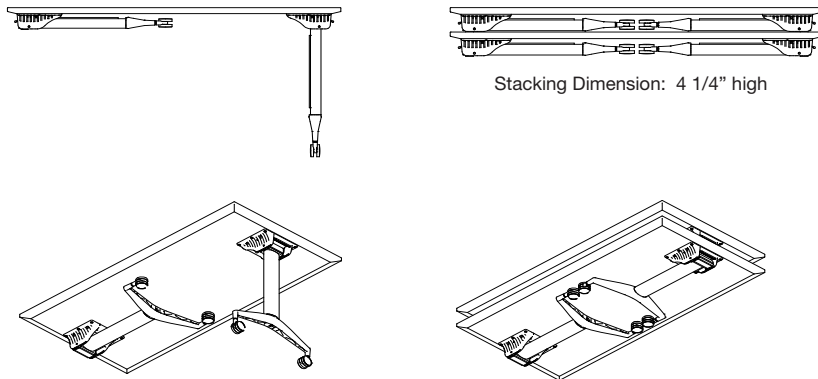

Stacking Dimension: 4 1/4" high



REVO | POWER OPTIONS



POWERPORT

The Revo Training PowerPort made from aluminum and featuring a hinged lid, provides a functional and attractive solution for connectivity. The PowerPort comes standard with 3 receptacles, 2 RJ45 jacks and a 10' heavy duty power cord.

The PowerPort is a UL/CSA-approved power/data power bar, (Port) which includes three 115-volt electrical convenience outlets, and two RJ45 communication ports - all easily accessed just under the worksurface. The PowerPort is Category 5/6 compatible. Folding tables cannot accommodate powerports or surface modules.

PORT

The Port alone (without the powerbar) serves as a large grommet for cable management, or to enable future power-up of the tables. It is 7.5" wide by 4" long, and features an aluminum hinged lid that is designed to be in the closed position when cables pass through to the plug-in. The Port can accommodate multiple cables at once, as well as transformer plugs, through the worksurface.

PowerPorts and Ports can be specified in 3 different locations (left, right or center) depending on the size of the training table surface. On surfaces that are smaller than 60", PowerPorts and Ports are available only in the center position.

See page 130 for options and location codes for selecting the PowerPort and Port location for each table top.

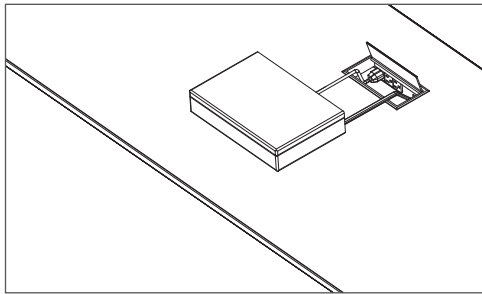

SURFACE MODULE

The Surface Module is a lower cost alternative to the PowerPort. It is compact and convenient and positions the plug-in on the work surface itself, instead of underneath it.

A Surface Module comes with two power receptacles above the work surface and one power receptacle below the work surface, which allows you to connect power to additional tables or configurations. In addition, the Surface Module also comes with two USB Ports -- one USB printer port, one RJ11 and one RJ45. Each receptacle has a 12 Amp, 120 Volt, 60 Hz capacity and comes standard with a 10' heavy duty power cord with a right angle plug. Folding tables cannot accommodate powerports or surface modules.

The Surface Module has an angled face that is easy to see and operate. The RJ45 Port allows connection to high speed DSL or Internet and provides access to cable modem, network or Internet router. In addition, a power plug exists for cell phone and laptop. There are two USB ports -- one for input and one for output to accommodate almost any electrical needs. The Surface Module is available in black finish only.

Surface Modules can be specified in three (3) different locations (Left, Right and Center) depending on the size of the meeting table surface. On surfaces that are smaller than 60", Surface Modules are available only in the centre position.

See page 130 for options and location codes for selecting the Surface Module location for each table top.



Below the worksurface

ROUND GROMMET

A round grommet with an open and shut mousehole serves to provide cable passage for areas not requiring a large opening.

Round grommet Silver Metallic, 60 mm diameter. (2 3/8" approx.)
Round grommets do not provide electrical service.

Grommets can be specified in 3 different locations (left, right or center) depending on the size of the meeting table surface.

On surfaces that are smaller than 60", grommets are available only in the center position.

One round grommet per table is provided at no charge, additional round grommets are available for an upcharge of **\$142 list** per grommet.





4-WIRE SYSTEM

The 4-wire System is a economical power distribution solution that is easy to specify, install, and re-configure.

Features:

- 4-wires, 2 circuits, 20 amps each
- 10 - duplex receptacles per circuit, 20 - 15 Amp receptacles per power infeed maximum
- Requires less space
- UL Listed as a Manufactured Wiring System
- More economical than 8-wire system
- RoHS Compliancy available upon request; Cradle to Cradle
- Can be used independently with grommet or 59PORT.



Model Numbers for 4-wire System

Circuit 1	Circuit 2	Description
59EC4-30-1	59EC4-30-2	4 wire, 2 circuit system for 30" table
59EC4-36-1	59EC4-36-2	4 wire, 2 circuit system for 36" table
59EC4-42-1	59EC4-42-2	4 wire, 2 circuit system for 42" table
59EC4-48-1	59EC4-48-2	4 wire, 2 circuit system for 48" table
59EC4-54-1	59EC4-54-2	4 wire, 2 circuit system for 54" table
59EC4-60-1	59EC4-60-2	4 wire, 2 circuit system for 60" table
59EC4-66-1	59EC4-66-2	4 wire, 2 circuit system for 66" table
59EC4-72-1	59EC4-72-2	4 wire, 2 circuit system for 72" table
59EC4-78-1	59EC4-78-2	4 wire, 2 circuit system for 78" table
59EC4-84-1	59EC4-84-2	4 wire, 2 circuit system for 84" table

4-WIRE SYSTEM

The 4-wire system can power a maximum of 10 duplex receptacles per circuit, 20 duplex receptacles total. With 2 duplex receptacles per table, this means that no more than 5 tables can be connected to one circuit (10 tables per 4-wire system). Once you have more than 10 tables powered with the 4-Trac® system, you must order another Power Entry (59EC4PE) and the related 4-wire harnesses to access a new circuit. Duplex receptacles are marked as circuit 1 or circuit 2. Unless specified, Krug will package as close as possible equal quantities of circuit 1 and 2 wiring harnesses.

All Krug's power access options can be used with or without the 4-wire Wire System. These components can be ordered together, or at a later date as your power requirements change.

Example 1: If you have a connected group of 7 (48" length) tables with a grommet in each, using the 4-wire system, you would order:

- One 4 wire, 2 circuit power entry (59EC4PE).
- Four tables will use circuit 1 harnesses (59EC4-48-1), which has two duplex receptacles per harness for a total of 8 duplex receptacles.
- Three tables will use circuit 2 harnesses (59EC-48-2), which has two duplex receptacles per harness for a total of 6 duplex receptacles.

Example 2: If you have a connected group of 11 (48" length) tables with a grommet in each, using the 4-wire system, you would order:

- Two 4 wire, 2 circuit power entry (59EC4PE).
- For the 1st power entry:
 - Three tables will use circuit 1 harnesses (59EC4-48-1), which has two duplex receptacles per harness for a total of 6 duplex receptacles.
 - Three tables will use circuit 2 harnesses (59EC-48-2), which has two duplex receptacles per harness for a total of 6 duplex receptacles.

For the 2nd power entry:

- Three tables will use circuit 1 harnesses (59EC4-48-1), which has two duplex receptacles per harness for a total of 6 duplex receptacles.
- Two tables will use circuit 2 harnesses (59EC-48-2), which has two duplex receptacles per harness for a total of 4 duplex receptacles.

4-WIRE - 42" JUMPERS

These longer jumper cables are required when connecting one table from the back to the end of another table using the 4-wire system. These jumper cables allow you to daisy chain each wired table to the next.



4-Trac® Power Entry

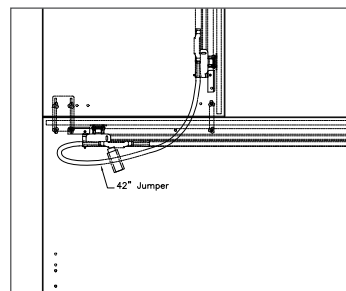
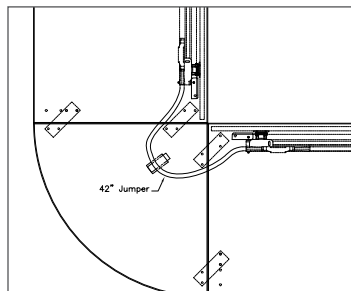



8-WIRE SYSTEM

The 8-wire Power System offers a high quality, cost effective answer to your power distribution needs. The modular system is adaptable to all architectural elements. The modularity of the System makes it simple to specify, order and install.

Features:

- UL recognized & listed
- Approved for use in New York City
- RoHS compliancy available upon request; cradle to cradle
- 20 Amp system available in 4 circuit configurations
- Allows for up to 40 duplex receptacles.
- Can be used independently with grommet or 59PORT.

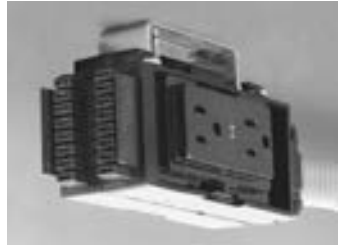

Model Numbers for 8-wire System

Circuit 1	Circuit 2	Circuit 3	Circuit 4	Description
59EC4-30-1	59EC4-30-2	59EC4-30-3	59EC4-30-4	8 wire, 4 circuit system for 30" table
59EC4-36-1	59EC4-36-2	59EC4-36-3	59EC4-36-4	8 wire, 4 circuit system for 36" table
59EC4-42-1	59EC4-42-2	59EC4-42-3	59EC4-42-4	8 wire, 4 circuit system for 42" table
59EC4-48-1	59EC4-48-2	59EC4-48-3	59EC4-48-4	8 wire, 4 circuit system for 48" table
59EC4-54-1	59EC4-54-2	59EC4-54-3	59EC4-54-4	8 wire, 4 circuit system for 54" table
59EC4-60-1	59EC4-60-2	59EC4-60-3	59EC4-60-4	8 wire, 4 circuit system for 60" table
59EC4-66-1	59EC4-66-2	59EC4-66-3	59EC4-66-4	8 wire, 4 circuit system for 66" table
59EC4-72-1	59EC4-72-2	59EC4-72-3	59EC4-72-4	8 wire, 4 circuit system for 72" table
59EC4-78-1	59EC4-78-2	59EC4-78-3	59EC4-78-4	8 wire, 4 circuit system for 78" table
59EC4-84-1	59EC4-84-2	59EC4-84-3	59EC4-84-4	8 wire, 4 circuit system for 84" table

8-WIRE SYSTEM

The 8-wire system can power a maximum of 10 duplex receptacles per circuit, 40 duplex receptacles total. With 2 duplex receptacles per table, this means that no more than 5 tables can be connected to one circuit (20 tables per 8-wire system). Once you have more than 20 tables powered with the 8-wire system, you must order another Power Entry (59EC8PE) and the related 8-wire harnesses to access a new circuit. Duplex receptacles are marked as circuit 1, 2, 3, or 4. Unless specified, as close as possible Krug will package equal quantities of Circuit 1, 2, 3, and 4 wiring harnesses.

All Krug's power access options can be used with or without the 8-wire Wire System. These components can be ordered together, or at a later date as your power requirements change.

For Example: If you have group of 16 (48" length) tables, using the 8-wire system, you would order: One 8 wire, 4 circuit power entry (59EC8PE).

- Four tables will use circuit 1 harnesses (59EC8-48-1), which has two duplex receptacles per harness for a total of 8 duplex receptacles.
- Four tables will use circuit 2 harnesses (59EC8-48-2), which has two duplex receptacles per harness for a total of 8 duplex receptacles.
- Four tables will use circuit 3 harnesses (59EC8-48-3), which has two duplex receptacles per harness for a total of 8 duplex receptacles.
- Four tables will use circuit 4 harnesses (59EC8-48-4), which has two duplex receptacles per harness for a total of 8 duplex receptacles.

8-WIRE - 42" JUMPERS

These longer jumper cables are required when connecting one table from the back to the end of another table using the 8-wire system. These jumper cables allow you to daisy chain each wired table to the next.



8-wire Power Entry

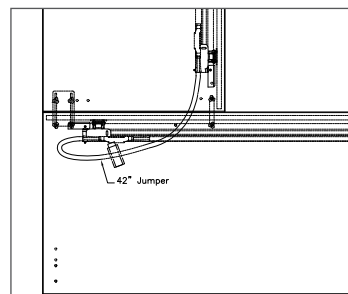
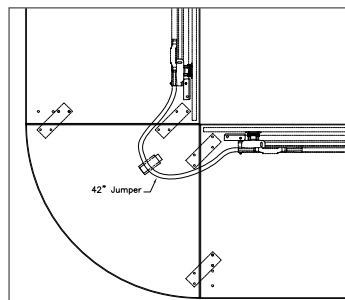

SCENARIO 1

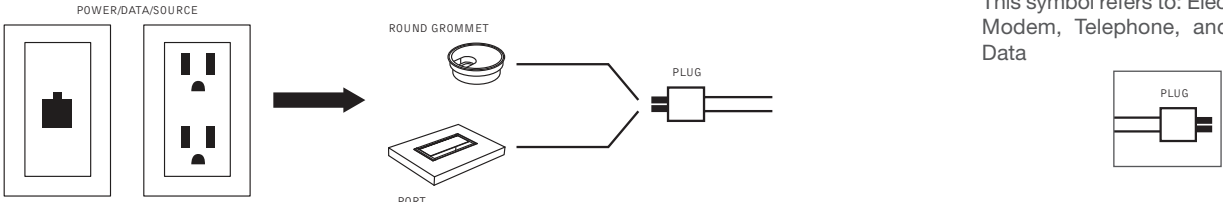

Scenario 1 is the simplest of connectivity solutions. You simply run your electrical and data cables down through the round grommet or port and plug directly into the power source.

SCENARIO 2

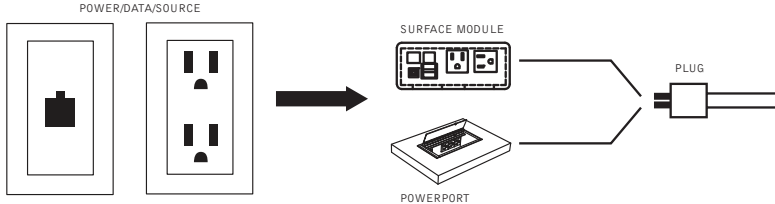

Scenario 2 demonstrates when powerports and surface modules are specified in the worksurfaces. Your electrical and data cables are plugged directly into these units. Both of these power options have 10' electrical cords and 14' data cables, that can be channelled through the cable management cavity in the leg and then plugged into the power source. Up to 10 powerports or surface modules can be daisy chained together from one power circuit, when the 14' data cables are not enough to reach the power source, data cables can be linked together with the use of a data hub. Please check local electrical regulations before linking these units.

SCENARIO 3

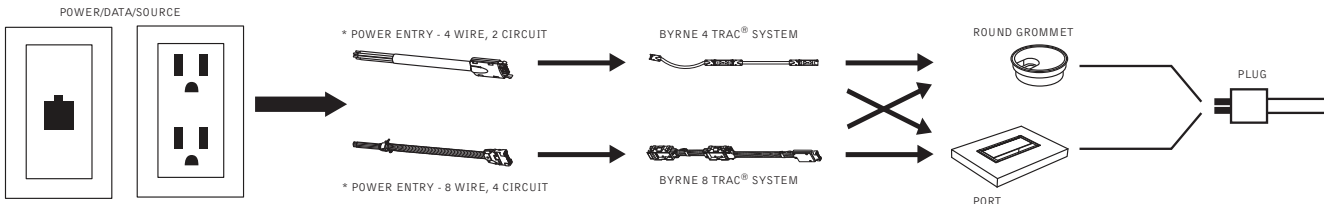

Scenario 3 illustrates the use of the 4 trac® and 8 trac® system. Your electrical and data cables are passed through the worksurface via the round grommet or port. The electrical equipment is plugged into the duplex receptacles located in the trac system.

The 4 trac system uses 2 circuits allowing 10 receptacles on the same circuit to be daisy chained together. Each trac system contains two duplex receptacles and can be specified with either circuit one or circuit two or both. Therefore, a maximum of 20 duplex receptacles can be used on two circuits. The 8 trac system works in the same manner, but uses 4 circuits instead of 2, allowing a maximum of 40 duplex receptacles to be used at one time.

*Power Entry is hardwired into the building source and can be channelled up the cable management cavity in the leg. The data cables run directly to the data source or linked together using a data hub.

SCENARIO 4

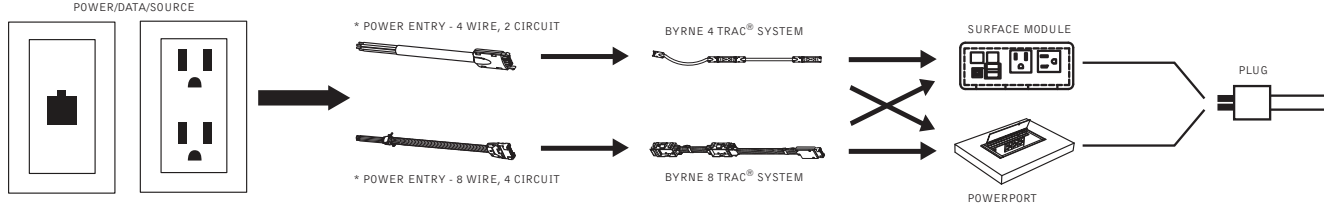

Scenario 4 demonstrates the use of the powerport or surface modules with the 4 trac® or 8 trac® system. Your electrical and data cables are plugged directly into either the powerport or surface module. The 10' power cord from these units are plugged into the duplex receptacles located in the trac system.

The 4 trac system uses 2 circuits allowing 10 receptacles on the same circuit to be daisy chained together. Each trac system contains two duplex receptacles and can be specified with either circuit one or circuit two or both. Therefore, a maximum of 20 duplex receptacles can be used on two circuits. The 8 trac system works in the same manner, but uses 4 circuits instead of 2, allowing a maximum of 40 duplex receptacles to be used at one time. When ordering powerports or surface modules on the worksurfaces, the duplex receptacles in these units need to be included in the receptacle count per circuit, otherwise the circuits will become overloaded.

*Power Entry is hardwired into the building source and can be channelled up the cable management cavity in the leg. The data cables run directly to the data source or linked together using a data hub.

REVO | POWER OPTIONS

Non-standard locations can be specified, although there are restrictions due to leg positions, and modesty panel positions. An upcharge of **\$142 list** per non-standard grommet is applicable. Contact Customer Service for assistance. Table Tops smaller than 60" have the power access available only in the "C" position. Table tops greater than 60" can have the power access specified in as many as three locations (AR, AL and C).

Position Code:

- AL – left corner
- AR – right corner
- C – center

POWERPORT/PORT POSITIONS

REVO TRAINING TABLES SMALLER THAN 60"

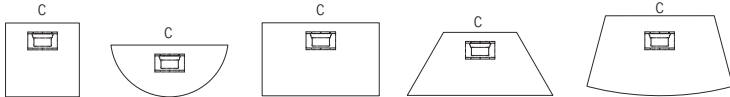

Square Half Round Rectangular Trapezoid Arc Trapezoid

REVO TRAINING TABLES 60" OR LARGER

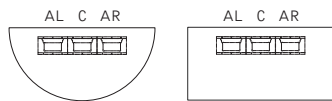

Half Round Rectangular

Modesty Panels are located on the same side as the PowerPort/Ports/Surface Modules. Modesty Panels are not available on 1/2 round and square tables. Folding tables cannot accommodate powerports.

SURFACE MODULE POSITIONS

REVO TRAINING TABLES SMALLER THAN 60"

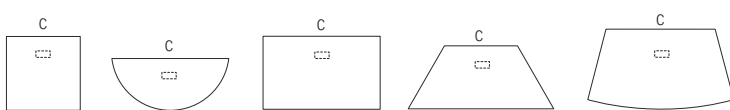

Square Half Round Rectangular Trapezoid Arc Trapezoid

REVO TRAINING TABLES 60" OR LARGER



Half Round Rectangular

Modesty Panels are located on the same side as the PowerPort/Ports/Surface Modules. Modesty Panels are not available on 1/2 round and square tables. Folding tables cannot accommodate surface modules.

STANDARD GROMMET POSITIONS

REVO TRAINING TABLES SMALLER THAN 60"

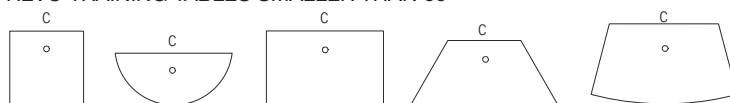

Square Half Round Rectangular Trapezoid Arc Trapezoid

REVO TRAINING TABLES 60" OR LARGER



Half Round Rectangular

Modesty Panels are shown on the same side as the Round Grommets. One round grommet per table is provided at no charge, additional round grommets are available for an upcharge of **\$142 list** per grommet in standard positions. Modesty Panels are not available on 1/2 round and square tables.

REVO | MODESTY PANEL & CABLE OPTIONS

MODESTY PANELS

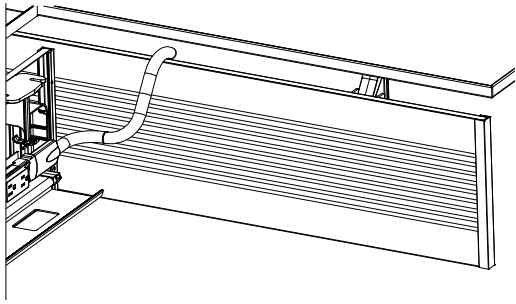

Track System, Modesty Panels for Power and Data Trough

Revo training tables have been designed with a 1-1/4" (32mm) space between the underside of the worksurface and the top edge of the modesty panel, eliminating the need for grommets in the modesty panels. This space makes it easy to pass cables from one table to another where modesty panels overlap at 90° corners, or where tables are positioned face to face. See typical examples below of cable management with different power options.

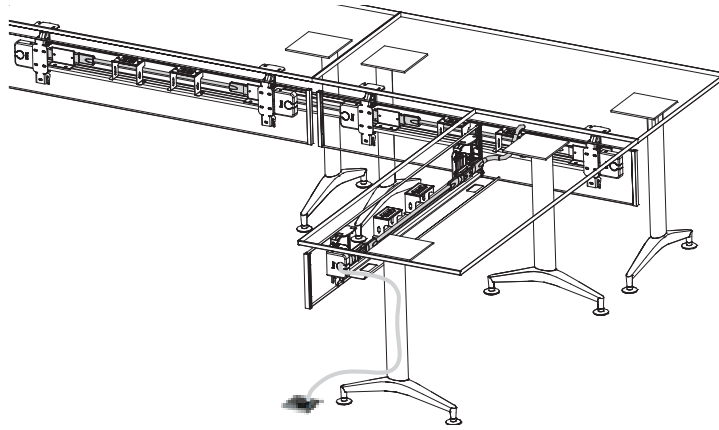

Power Ports & Modesty Panels with no Cable Management Trough

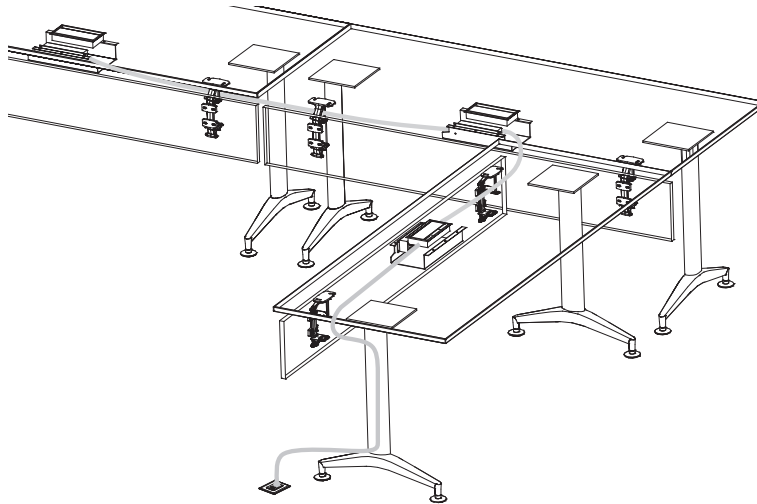

CABLE MANAGEMENT

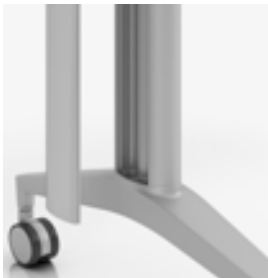

REVO leg
Snap on Cover









Cable management

Cables are channeled through the leg and concealed with a snap-on cover which allows cord access to the top and bottom when required.

Legs are available in two cable management sizes, standard and high capacity, determined by the users' requirements.

Standard cable managers have 1.5 in² of cable management capacity. High capacity cable managers have 2.4 in² of cable management capacity.

REVO | SEATING CAPACITIES

DESCRIPTION	TOP SIZE		APPROX. SEATING FOR LONG SIDE	APPROX.	
	LENGTH	WIDTH		TOTAL SEATING FOR STAND ALONE WITHOUT MODESTY	
Half Round 	48	24	2	2	
	60	30	2	2	
	72	36	2	2	
Square 	30	30	1	2	
	36	36	1	2	
Rectangular 	48	20	1	2	
	54	20	1	2	
	60	20	2	4	
	66	20	2	4	
	72	20	2	4	
	78	20	2	4	
	84	20	3	6	
	48	24	1	2	
	54	24	1	2	
	60	24	2	4	
	66	24	2	4	
	72	24	2	4	
	78	24	2	4	
	84	24	3	6	
	48	30/36	1	2	
	54	30/36	1	2	
	60	30/36	2	4	
66	30/36	2	4		
72	30/36	2	4		
78	30/36	2	4		
84	30/36	3	6		
Trapezoid 	48	24	1	2	
	60	30	1	2	
	72	36	1	2	
Arc Trapezoid 	48	24	1	2	
	60	24	2	2	
	72	24	2	2	
	60	30	2	2	
	72	30	2	2	
	60	36	2	2	
	72	36	2	2	
Corner	45°	24	24	1	N/A
Connecting Top 		30	30	1	N/A
		36	36	1	N/A
	60°	24	24	1	N/A
		30	30	1	N/A
		36	36	1	N/A
	90°	24	24	1	N/A
		30	30	1	N/A
		36	36	1	N/A

ORDERING NOTES

If a modesty panel is used, there is no seating capacity on that side of the table. There is no seating on the ends due to base locations. Seating on the ends of a 84" tables is possible since the bases are inset 15" from the ends. To establish seating capacities, an outside chair dimension of 24" has been used, plus an allowance of 5" between chairs, for a total of 29". This is an approximation and based on seating with 5 prong bases. When using chairs with different specifications be sure to adjust the approximate seating capacity accordingly. Since not all manufacturers use this same seating formula, when a seating capacity is in question, please contact Krug Customer Service to review the specific seating that is being used with Krug Revo Training product.

REVO | EXAMPLE TABLE CONFIGURATIONS

This is a sampling of some of the possible configurations in the REVO Training Table Line

RECTANGULAR TABLES



Model Number Qty.
59THRT7236 4

RECTANGULAR TABLES



Model Number Qty.
59THRT7236 2
59THRT7224 2

HALF ROUND TABLES

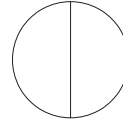

Model Number Qty.
59THDH6030 2

HALF ROUND WITH RECTANGULAR TABLES



Model Number Qty.
59THDH6030 2
59THRT6030 2

TRAPEZOID TABLES

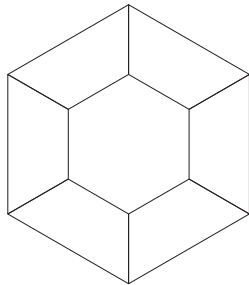

Model Number Qty.
59THTZ7236 6

60° CORNER CONNECTOR TOPS WITH TRAPEZOID TABLES

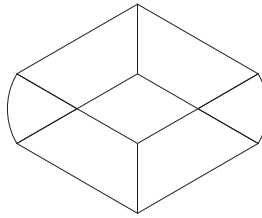

Model Number Qty.
59TC303060 2
59THTZ6030 4

TRAPEZOID TABLES WITH RECTANGULAR TABLES

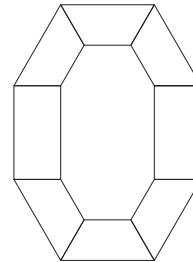

Model Number Qty.
59THTZ6030 6
59THRT6030 2

90° CORNER CONNECTOR TOP WITH RECTANGULAR TABLES

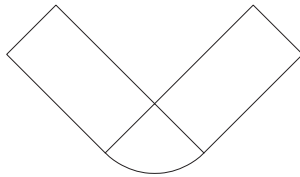

Model Number Qty.
59TC363690 1
59THRT7236 2

90° CORNER CONNECTOR TOPS WITH RECTANGULAR TABLES

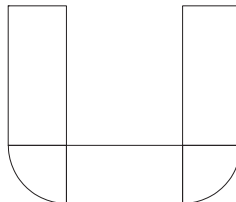

Model Number Qty.
59TC303090 2
59THRT6030 1
59THRT7230 2

90° CORNER CONNECTOR TOPS WITH RECTANGULAR TABLES

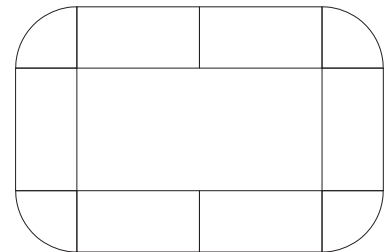

Model Number Qty.
59TC363690 4
59THRT7236 6

TRAPEZOID TABLES WITH RECTANGULAR TABLES

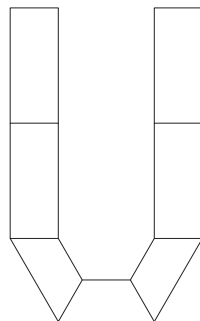

Model Number Qty.
59THTZ6030 3
59THRT6030 4

60° CORNER CONNECTOR TOPS WITH RECTANGULAR TABLES

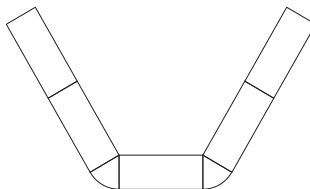

Model Number Qty.
59TC242460 2
59THRT6024 5

45° CORNER CONNECTOR TOPS WITH RECTANGULAR TABLES

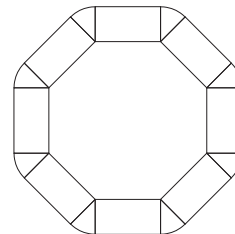

Model Number Qty.
59TC242445 8
59THRT4824 8

REVO | RECTANGULAR TABLES W/ FIXED C & T BASES

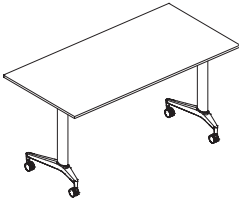
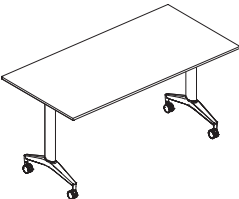
Description	Model	Laminate W/ PVC Edge	Rift Oak, Cherry, Walnut, Maple	W	D	H	KW	Shipping Weight	Cubic Feet
 <p>C-base inset from ends: 72" tables & smaller - 3" 78" tables - inset 6" 84" tables - inset 15"</p>	59THRT4820CB_W_	1266	1660	47.75	19.75	29.25	36.5	62	5
	59THRT5420CB_W_	1294	1693	53.75	19.75	29.25	42.5	65	5.5
	59THRT6020CB_W_	1321	1726	59.75	19.75	29.25	48.5	69	5.5
	59THRT6620CB_W_	1417	1832	65.75	19.75	29.25	54.5	76	6
	59THRT7220CB_W_	1470	1901	71.75	19.75	29.25	60.5	82	6
	59THRT7820CB_W_	1527	1977	77.75	19.75	29.25	60.5	83	6.5
	59THRT8420CB_W_	1585	2051	83.75	19.75	29.25	48.5	84	7
	59THRT4824CB_W_	1313	1713	47.75	23.75	29.25	36.5	68	5.5
	59THRT5424CB_W_	1345	1751	53.75	23.75	29.25	42.5	73	6
	59THRT6024CB_W_	1375	1790	59.75	23.75	29.25	48.5	77	6
	59THRT6624CB_W_	1482	1895	65.75	23.75	29.25	54.5	80	6.5
	59THRT7224CB_W_	1546	1958	71.75	23.75	29.25	60.5	91	6.5
	59THRT7824CB_W_	1606	2033	77.75	23.75	29.25	60.5	92	7
	59THRT8424CB_W_	1666	2114	83.75	23.75	29.75	48.5	93	7.5
	59THRT4830CB_W_	1400	1777	47.75	29.75	29.25	36.5	77	6
	59THRT5430CB_W_	1422	1826	53.75	29.75	29.25	42.5	81	6.5
	59THRT6030CB_W_	1446	1872	59.75	29.75	29.25	48.5	88	6.5
	59THRT6630CB_W_	1548	1985	65.75	29.75	29.25	54.5	90	7
	59THRT7230CB_W_	1608	2058	71.75	29.75	29.25	60.5	104	7.5
	59THRT7830CB_W_	1669	2129	77.75	29.75	29.25	60.5	107	8
59THRT8430CB_W_	1728	2202	83.75	29.75	29.25	48.5	109	8	
 <p>T-base inset from ends: 72" tables & smaller - 3" 78" tables - inset 6" 84" tables - inset 15"</p>	59THRT4824TB_W_	1345	1751	47.75	23.75	29.25	36.5	68	5.5
	59THRT5424TB_W_	1375	1790	53.75	23.75	29.25	42.5	73	6
	59THRT6024TB_W_	1482	1895	59.75	23.75	29.25	48.5	77	6
	59THRT6624TB_W_	1546	1958	65.75	23.75	29.25	54.5	80	6.5
	59THRT7224TB_W_	1606	2033	71.75	23.75	29.25	60.5	91	6.5
	59THRT7824TB_W_	1666	2114	77.75	23.75	29.25	60.5	92	7
	59THRT8424TB_W_	1728	2202	83.75	23.75	29.25	48.5	93	7.5
	59THRT4830TB_W_	1400	1777	47.75	29.75	29.25	36.5	77	6
	59THRT5430TB_W_	1422	1826	53.75	29.75	29.25	42.5	81	6.5
	59THRT6030TB_W_	1446	1872	59.75	29.75	29.25	48.5	88	6.5
	59THRT6630TB_W_	1548	1985	65.75	29.75	29.25	54.5	90	7
	59THRT7230TB_W_	1608	2058	71.75	29.75	29.25	60.5	104	7.5
	59THRT7830TB_W_	1669	2129	77.75	29.75	29.25	60.5	107	8
	59THRT8430TB_W_	1728	2202	83.75	29.75	29.25	48.5	109	8
	59THRT4836TB_W_	1493	1921	47.75	35.75	29.25	36.5	91	8
	59THRT5436TB_W_	1541	1977	53.75	35.75	29.25	42.5	98	8.5
	59THRT6036TB_W_	1586	2030	59.75	35.75	29.25	48.5	104	9
	59THRT6636TB_W_	1691	2149	65.75	35.75	29.25	54.5	113	9.5
	59THRT7236TB_W_	1751	2229	71.75	35.75	29.25	60.5	122	9.5
	59THRT7836TB_W_	1814	2306	77.75	35.75	29.25	60.5	126	10
59THRT8436TB_W_	1874	2377	83.75	35.75	29.25	48.5	130	10	

ORDERING NOTES:

To order bases with glides, replace the 1st underscore in the model number with the letter "G"; e.g. "59THRT7224CBGW".

To order bases with casters, replace the 1st underscore in the model number with the letter "C"; e.g. "59THRT7224CBCW".

To order the standard cable manager replace the 2nd underscore in the model number with the number "1"; e.g. "59THRT7224CBGW1".

To order the high capacity base cable manager replace the 2nd underscore in the model number with the number "2". e.g. "59THRT7224CBCW2".

ORDERING PROCEDURE

To order, please specify the following:

- 1) Krug product model number
- 2) Wood species and finish or Laminate
- 3) Grommet location and style if applicable
- 4) Edge profile - D or T
(Knife Edge is optional on Wood and Laminate work-surfaces for an upcharge of \$153 list per table.)
- 5) Modesty Panel if applicable (see page 147)

*indicates model illustrated by line drawing.

KRUG EXPRESS

See page 346 for Krug Express program.

STANDARD FINISHES

For a complete list of standard finishes, please see page 347 for Standard Wood Finishes or In-Stock Laminates.

MODESTY PANELS

Please see page 147 for options and upcharges.

VENEER TOPS

Please note when ordering wood veneer tables, these tables can only be ordered with a wood edge.

REVO | TRAPEZOID TABLES W/ FIXED C & T BASES

Description	Model	Laminate W/ PVC Edge	Rift Oak, Cherry, Walnut, Maple	W	D	H	KW	Shipping Cubic			
			Weight					Feet	X	Y	
Trapezoid Table w/ Fixed C - Base. Casters or Glides - No Modesty Panel	59THTZ4824CB_W_	1396	1789	47.75	20.75	29.25	21.5	56	5.5	23.75	23.75
	59THTZ6030CB_W_	1526	1917	59.75	25.75	29.25	27.75	69	6.5	29.75	29.75
	59THTZ7236CB_W_	1772	2221	71.75	31	29.25	35.75	84	7.5	35.75	35.75

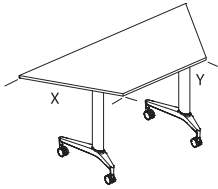

Trapezoid Table w/ Fixed T - Base. Casters or Glides - No Modesty Panel	59THTZ6030TB_W_	1526	1917	59.75	25.75	29.25	27.75	69	6.5	29.75	29.75
	59THTZ7236TB_W_	1772	2221	71.75	31	29.25	35.75	84	7.5	35.75	35.75

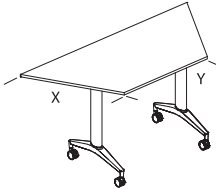

ORDERING NOTES:

To order bases with glides, replace the 1st underscore in the model number with the letter “G”; e.g. 59THRT7224CBGW_.

To order bases with casters, replace the 1st underscore in the model number with the letter “C”; e.g. 59THRT7224CBCW_.

To order the standard cable manager replace the 2nd underscore in the model number with the number “1”; e.g. 59THRT7224CBGW1.

To order the high capacity base cable manager replace the 2nd underscore in the model number with the number “2”; e.g. 59THRT7224CBCW2.

ORDERING PROCEDURE

To order, please specify the following:

- 1) Krug product model number
- 2) Wood species and finish or Laminate
- 3) Grommet location and style if applicable
- 4) Edge profile - D or T
(Knife Edge is optional on Wood and Laminate work-surfaces for a upcharge of **150 list** per table.
- 5) Modesty Panel if applicable (see page 147)

*indicates model illustrated by line drawing.

KRUG EXPRESS

See page 346 for Krug Express program.

STANDARD FINISHES

For a complete list of standard finishes, please see page 347 for Standard Wood Finishes or In-Stock Laminates.

MODESTY PANELS

Please see page 147 for options and upcharges.

VENEER TOPS

Please note when ordering wood veneer tables, these tables can only be ordered with a wood edge.

REVO | ARCED TRAPEZOID TABLES W/ FIXED C & T BASES

Description	Model	Laminate W/ PVC Edge	Rift Oak, Cherry, Walnut, Maple	W	D	H	KW	Shipping Cubic			
								Weight	Feet	X	Y
Arced Trapezoid Table w/ Fixed C - Base. Casters or Glides - No Modesty Panel	59THAZ4824CB_W_	1452	1835	47.75	23.5	29.25	20.5	59	5.5	23.75	23.75
	59THAZ6024CB_W_	1516	1916	59.75	23.5	29.25	32.25	67	6	23.75	35.75
	59THAZ7224CB_W_	1659	2116	71.75	23.5	29.25	44.25	75	6.5	23.75	47.75
	59THAZ6030CB_W_	1526	1955	59.75	28.5	29.25	29.25	72	6.5	29.75	29.75
	59THAZ7230CB_W_	1721	2171	71.75	28.5	29.25	41.25	82	7	29.75	41.75

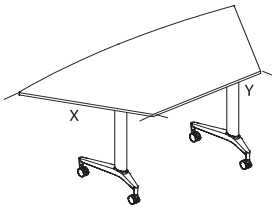

Arced Trapezoid Table w/ Fixed T - Base. Casters or Glides - No Modesty Panel	59THAZ4824TB_W_	1452	1835	47.75	23.5	29.25	20.5	59	5.5	23.75	23.75
	59THAZ6024TB_W_	1516	1916	59.75	23.5	29.25	32.25	67	6	23.75	35.75
	59THAZ7224TB_W_	1659	2116	71.75	23.5	29.25	44.25	75	6.5	23.75	47.75
	59THAZ6030TB_W_	1526	1955	59.75	28.5	29.25	29.25	72	6.5	29.75	29.75
	59THAZ7230TB_W_	1721	2171	71.75	28.5	29.25	41.25	82	7	29.75	41.75
	59THAZ6036TB_W_	1630	2038	59.75	33.75	29.25	26	76	7	35.75	23.75
	59THAZ7236TB_W_	1807	2259	71.75	33.75	29.25	37.75	88	7.5	35.75	35.75

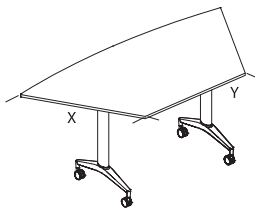

ORDERING NOTES: To order bases with glides, replace the 1st underscore in the model number with the letter “G”; e.g. “59THZ6030CBGW”.

To order bases with casters, replace the 1st underscore in the model number with the letter “C”; e.g. “59THZ6030CBCW”.

To order the standard cable manager replace the 2nd underscore in the model number with the number “1”; e.g. “59THZ6030CBGW1”.

To order the high capacity base cable manager replace the 2nd underscore in the model number with the number “2”; e.g. “59THZ6030CBCW2”.

DIMENSION KEY

W – width
D – depth
H – height of worksurface
KW – kneehole width
X & Y – dimensions as indicated on line drawing

Dimensions are in inches and approximate.
Contact Customer Service if dimensions are critical.

KRUG EXPRESS

See page 346 for Krug Express program.

STANDARD FINISHES

For a complete list of standard finishes, please see page 347 for Standard Wood Finishes or In-Stock Laminates.

MODESTY PANELS

Please see page 147 for options and upcharges.

VENEER TOPS

Please note when ordering wood veneer tables, these tables can only be ordered with a wood edge.

REVO | HALF ROUND TABLES W/ FIXED C & T BASES SQUARE TABLES W/ FIXED T BASE

Description	Model	Laminate W/ PVC Edge	Rift Oak, Cherry, Walnut, Maple	W	D	H	KW	Shipping Cubic			
								Weight	Feet	X	Y
Half Round Table w/ Fixed C - Base. Casters or Glides - No Modesty Panel	59THDH4824CB_W_	1344	1745	47.75	23.75	29.25	30	60	5	-	-
	59THDH6030CB_W_	1553	1910	59.75	29.75	29.25	33.25	76	6.5	-	-
	59THDH7236CB_W_	1729	2214	71.75	35.75	29.25	45.25	95	8	-	-

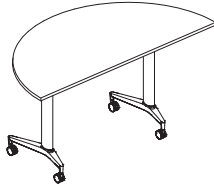

Half Round Table w/ Fixed T - Base. Casters or Glides - No Modesty Panel	59THDH6030TB_W_	1553	1910	59.75	29.75	29.25	33.25	76	6.5	-	-
	59THDH7236TB_W_	1729	2214	71.75	35.75	29.25	45.25	95	8	-	-



Square Table w/ Fixed T - Base. Casters or Glides - No Modesty Panel	59THSQ3030TB_W_	1403	1761	29.75	29.75	29.25	24.5	59	4	-	-
	59THSQ3636TB_W_	1422	1827	35.75	35.75	29.25	24.5	71	4.5	-	-

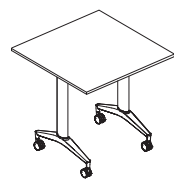

ORDERING NOTES: To order bases with glides, replace the 1st underscore in the model number with the letter “G”; e.g. “59THRT7224CBGW_”.

To order bases with casters, replace the 1st underscore in the model number with the letter “C”; e.g. “59THRT7224CBCW_”.

To order the standard cable manager replace the 2nd underscore in the model number with the number “1”; e.g. “59THRT7224CBGW1”.

To order the high capacity base cable manager replace the 2nd underscore in the model number with the number “2”; e.g. “59THRT7224CBCW2”.

DIMENSION KEY

W – width
D – depth
H – height of worksurface
KW – kneehole width
X & Y – dimensions as indicated on line drawing

Dimensions are in inches and approximate.
Contact Customer Service if dimensions are critical.

KRUG EXPRESS

See page 346 for Krug Express program.

STANDARD FINISHES

For a complete list of standard finishes, please see page 347 for Standard Wood Finishes or In-Stock Laminates.

MODESTY PANELS

Modesty panels are not available on half round and square tables.

VENEER TOPS

Please note when ordering wood veneer tables, these tables can only be ordered with a wood edge.

REVO | RECTANGULAR NESTING TABLES W/ C & T BASES

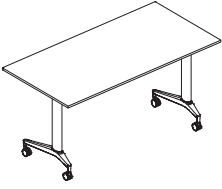
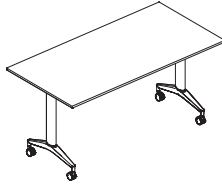
Description	Model	Laminate W/ PVC Edge	Rift Oak, Cherry, Walnut, Maple	W	D	H	KW	Shipping Weight	Cubic Feet	X	Y	
	Rectangular Nesting Table w/ C - Base.	59THRT4820CBFP_W_	1727	2119	47.75	19.75	29.25	36.5	62	5	-	-
	59THRT5420CBFP_W_	1756	2154	53.75	19.75	29.25	42.5	65	5.5	-	-	
	Casters or Glides - No Modesty Panel	59THRT6020CBFP_W_	1784	2187	59.75	19.75	29.25	48.5	69	5.5	-	-
	59THRT6620CBFP_W_	2075	2480	65.75	19.75	29.25	54.5	76	6	-	-	
	59THRT7220CBFP_W_	2122	2539	71.75	19.75	29.25	60.5	82	6	-	-	
	59THRT7820CBFP_W_	2180	2606	77.75	19.75	29.25	72.5	83	6.5	-	-	
	59THRT8420CBFP_W_	2241	2680	83.75	29.75	29.25	48.5	84	7	-	-	
	59THRT4824CBFP_W_	1776	2177	47.75	23.75	29.25	36.5	68	5.5	-	-	
	59THRT5424CBFP_W_	1809	2216	53.75	23.75	29.25	42.5	73	6	-	-	
	59THRT6024CBFP_W_	1841	2256	59.75	23.75	29.25	48.5	77	6	-	-	
	59THRT6624CBFP_W_	2143	2556	65.75	23.75	29.25	54.5	80	6.5	-	-	
	59THRT7224CBFP_W_	2203	2615	71.75	23.75	29.25	60.5	91	6.5	-	-	
	59THRT7824CBFP_W_	2260	2674	77.75	23.75	29.25	72.5	92	7	-	-	
	59THRT8424CBFP_W_	2320	2732	83.75	23.75	29.25	48.5	93	7.5	-	-	
	59THRT4830CBFP_W_	1862	2244	47.75	29.75	29.25	36.5	77	6	-	-	
	59THRT5430CBFP_W_	1887	2289	53.75	29.75	29.25	42.5	81	6.5	-	-	
	59THRT6030CBFP_W_	1910	2336	59.75	29.75	29.25	48.5	88	6.5	-	-	
	C-base inset from ends: 72" tables & smaller - 3"	59THRT6630CBFP_W_	2209	2646	65.75	29.75	29.25	54.5	90	7	-	-
	78" tables - inset 6"	59THRT7230CBFP_W_	2265	2716	71.75	29.75	29.25	60.5	104	7.5	-	-
	84" tables - inset 15"	59THRT7830CBFP_W_	2323	2782	77.75	29.75	29.25	60.5	107	8	-	-
59THRT8430CBFP_W_	2475	2882	83.75	29.75	29.25	48.5	109	8	-	-		
	Rectangular Nesting Table w/ T- Base.	59THRT4824TBFP_W_	1776	2177	47.75	23.75	29.25	36.5	68	5.5	-	-
	59THRT5424TBFP_W_	1809	2216	53.75	23.75	29.25	42.5	73	6	-	-	
	Casters or Glides No Modesty Panel	59THRT6024TBFP_W_	1841	2256	59.75	23.75	29.25	48.5	77	6	-	-
	59THRT6624TBFP_W_	2143	2556	65.75	23.75	29.25	54.5	80	6.5	-	-	
	59THRT7224TBFP_W_	2203	2615	71.75	23.75	29.25	60.5	91	6.5	-	-	
	59THRT7824TBFP_W_	2260	2674	77.75	23.75	29.25	60.5	92	7	-	-	
	59THRT8424TBFP_W_	2320	2732	83.75	23.75	29.25	48.5	93	7.5	-	-	
	59THRT4830TBFP_W_	1862	2244	47.75	29.75	29.25	36.5	77	6	-	-	
	59THRT5430TBFP_W_	1887	2289	53.75	29.75	29.25	42.5	81	6.5	-	-	
	59THRT6030TBFP_W_	1910	2336	59.75	29.75	29.25	48.5	88	6.5	-	-	
	59THRT6630TBFP_W_	2209	2646	65.75	29.75	29.25	54.5	90	7	-	-	
	59THRT7230TBFP_W_	2265	2716	71.75	29.75	29.25	60.5	104	7.5	-	-	
	59THRT7830TBFP_W_	2418	2823	77.75	29.75	29.25	60.5	107	8	-	-	
	59THRT8430TBFP_W_	2475	2882	83.75	29.75	29.25	48.5	109	8	-	-	
	59THRT4836TBFP_W_	1940	2369	47.75	35.75	29.25	36.5	91	8	-	-	
	59THRT5436TBFP_W_	1986	2422	53.75	35.75	29.25	42.5	98	8.5	-	-	
	59THRT6036TBFP_W_	2034	2476	59.75	35.75	29.25	48.5	104	9	-	-	
	T-base inset from ends: 72" tables & smaller - 3"	59THRT6636TBFP_W_	2334	2792	65.75	35.75	29.25	54.5	113	9.5	-	-
	78" tables - inset 6"	59THRT7236TBFP_W_	2392	2867	71.75	35.75	29.25	60.5	122	9.5	-	-
	84" tables - inset 15"	59THRT7836TBFP_W_	2450	2942	77.75	35.75	29.25	60.5	126	10	-	-
59THRT8436TBFP_W_	2509	3014	83.75	35.75	29.25	48.5	130	10	-	-		

ORDERING NOTES: To order bases with glides, replace the 1st underscore in the model number with the letter "G"; e.g. "59THRT7224CBFPGW_".

To order bases with casters, replace the 1st underscore in the model number with the letter "C"; e.g. "59THRT7224CBFPCW_".

To order the standard cable manager replace the 2nd underscore in the model number with the number "1"; e.g. "59THRT7224CBFPGW1".

DIMENSION KEY

W - width
D - depth
H - height of worksurface
KW - kneehole width
X & Y - dimensions as indicated on line drawing

Dimensions are in inches and approximate.
Contact Customer Service if dimensions are critical.

KRUG EXPRESS

See page 346 for Krug Express program.

STANDARD FINISHES

For a complete list of standard finishes, please see page 347 for Standard Wood Finishes or In-Stock Laminates.

MODESTY PANELS

Please see page 147 for options and upcharges.

VENEER TOPS

Please note when ordering wood veneer tables, these tables can only be ordered with a wood edge.

REVO | TRAPEZOID NESTING TABLES W/ C & T BASES

Description	Model	Laminate W/ PVC Edge	Rift Oak, Cherry, Walnut, Maple	W	D	H	KW	Shipping Cubic			
								Weight	Feet	X	Y
Trapezoid Nesting Table w/ C - Base.	59THTZ4824CBFP_W_	1857	2248	47.75	20.75	29.25	18.25	56	5.5	23.75	23.75
Casters or Glides - No Modesty Panel	59THTZ6030CBFP_W_	1990	2382	59.75	20.75	29.25	24.5	69	6.5	29.75	29.75
	59THTZ7236CBFP_W_	2294	2746	71.75	31	29.25	32.5	84	7.5	35.75	35.75

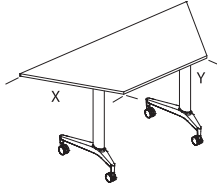

Trapezoid Nesting Table w/ T - Base.	59THZ6030TBFP_W_	1990	2382	59.75	20.75	29.25	27.5	69	6.5	29.75	29.75
Casters or Glides - No Modesty Panel	59THZ7236TBFP_W_	2294	2746	71.75	31	29.25	35.75	84	7.5	35.75	35.75

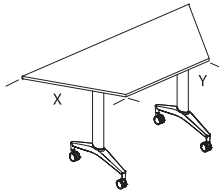

ORDERING NOTES: To order bases with glides, replace the 1st underscore in the model number with the letter “G”; e.g. “59THRT7224CBFPGW_”.

To order bases with casters, replace the 1st underscore in the model number with the letter “C”; e.g. “59THRT7224CBFCW_”.

To order the standard cable manager replace the 2nd underscore in the model number with the number “1”; e.g. “59THRT7224CBFP-W1”.

To order the high capacity base cable manager replace the 2nd underscore in the model number with the number “2”; e.g. “59THRT7224CBFCW2”.

DIMENSION KEY

W – width
D – depth
H – height of worksurface
KW – kneehole width
X & Y – dimensions as indicated on line drawing

Dimensions are in inches and approximate.
Contact Customer Service if dimensions are critical.

KRUG EXPRESS

See page 346 for Krug Express program.

STANDARD FINISHES

For a complete list of standard finishes, please see page 347 for Standard Wood Finishes or In-Stock Laminates.

MODESTY PANELS

Please see page 147 for options and upcharges.

VENEER TOPS

Please note when ordering wood veneer tables, these tables can only be ordered with a wood edge.

REVO | ARCED TRAPEZOID NESTING TABLES W/ C & T BASES

Description	Model	Laminate W/ PVC Edge	Rift Oak, Cherry, Walnut, Maple	W	D	H	KW	Shipping Cubic			
								Weight	Feet	X	Y
Arced Trapezoid Nesting Table w/ C - Base.	59THAZ4824CBFP_W_	1917	2300	47.75	23.5	29.25	17.25	59	5.5	23.75	23.75
Casters or Glides - No Modesty Panel	59THAZ6024CBFP_W_	1980	2381	59.75	23.5	29.25	29	67	6	23.75	35.75
	59THAZ7224CBFP_W_	2122	2580	71.75	23.5	29.25	41	75	6.5	23.75	47.75
	59THAZ6030CBFP_W_	1990	2420	59.75	28.5	29.25	26	72	6.5	29.75	29.75
	59THAZ7230CBFP_W_	2186	2635	71.75	28.5	29.25	38	82	7	29.75	41.75

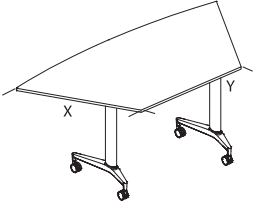

Arced Trapezoid Nesting Table w/ T - Base. Casters or Glides - No Modesty Panel	59THAZ4824TBFP_W_	1917	2300	47.75	23.5	29.25	20.5	59	5.5	23.75	23.75
	59THAZ6024TBFP_W_	1980	2381	59.75	23.5	29.25	32.25	67	6	23.75	35.75
	59THAZ7224TBFP_W_	2122	2580	71.75	23.5	29.25	44.25	75	6.5	23.75	47.75
	59THAZ6030TBFP_W_	1990	2420	59.75	28.5	29.25	29.25	72	6.5	29.75	29.75
	59THAZ7230TBFP_W_	2186	2635	71.75	28.5	29.25	41.25	82	7	29.75	41.75
	59THAZ6036TBFP_W_	2094	2504	59.75	33.75	29.25	26	76	7	35.75	23.75
	59THAZ7236TBFP_W_	2273	2724	71.75	33.75	29.25	37.75	88	7.5	35.75	35.75

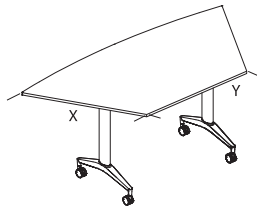

ORDERING NOTES: To order bases with glides, replace the 1st underscore in the model number with the letter “G”;

e.g. “59THZ6030CBFPGW_”.

To order bases with casters, replace the 1st underscore in the model number with the letter “C”; e.g. “59THZ6030CBFPCW_”.

To order the standard cable manager replace the 2nd underscore in the model number with the number “1”; e.g. “59THZ6030CBFPGW1”.

To order the high capacity base cable manager replace the 2nd underscore in the model number with the number “2”;

e.g. “59THZ6030CBFPCW2”.

DIMENSION KEY

W – width
D – depth
H – height of worksurface
KW – kneehole width
X & Y – dimensions as indicated on line drawing

Dimensions are in inches and approximate.
Contact Customer Service if dimensions are critical.

KRUG EXPRESS

See page 346 for Krug Express program.

STANDARD FINISHES

For a complete list of standard finishes, please see page 347 for Standard Wood Finishes or In-Stock Laminates.

MODESTY PANELS

Please see page 147 for options and upcharges.

VENEER TOPS

Please note when ordering wood veneer tables, these tables can only be ordered with a wood edge.

REVO | HALF ROUND NESTING TABLES W/ C & T BASES CORNER CONNECTING TOPS

Description	Model	Laminate W/ PVC Edge	Rift Oak, Cherry, Walnut, Maple	W	D	H	KW	Shipping			
			Weight					Feet	X Y		
Half Round Nesting Table w/C - Base. Casters or Glides - No Modesty Panel	59THDH4824CBFP_W_	1804	2205	47.75	23.75	29.25	30	60	5	-	-
	59THDH6030CBFP_W_	2018	2376	59.75	29.75	29.25	33.25	76	6.5	-	-
	59THDH7236CBFP_W_	2194	2679	71.75	35.75	29.25	45.25	95	8	-	-

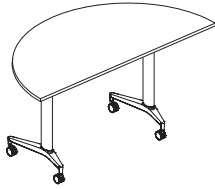

Half Round Nesting Table w/T - Base. Casters or Glides - No Modesty Panel	59THDH6030TBFP_W_	2018	2376	59.75	29.75	29.25	33.25	76	6.5	-	-
	59THDH7236TBFP_W_	2194	2679	71.75	35.75	29.25	45.25	95	8	-	-



45° Corner Tops	59TC242445	386	424	18.25	23.75	29.25	18.25	21	2.5	-	-
	59TC303045	408	449	22.75	35.75	29.25	22.75	27	3.5	-	-
	59TC363645	436	478	27.75	35.75	29.25	27.25	36	4.5	-	-



60° Corner Tops	59TC242460	436	478	23.75	23.75	29.25	23.75	27	3	-	-
	59TC303060	462	507	29.75	29.75	29.25	29.75	36	4	-	-
	59TC363660	494	545	35.75	35.75	29.25	35.75	44	5.5	-	-

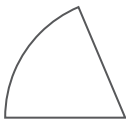

ORDERING NOTES: To order bases with glides, replace the 1st underscore in the model number with the letter “G”; e.g. “59THRT7224CBFDGW_”.

To order bases with casters, replace the 1st underscore in the model number with the letter “C”; e.g. “59THRT7224CBFDCW_”.

To order the standard cable manager replace the 2nd underscore in the model number with the number “1”; e.g. “59THRT7224CBFDGW1”.

To order the high capacity base cable manager replace the 2nd underscore in the model number with the number “2”; e.g. “59THRT7224CBFDCW2”.

Please note that modesty panels are not available on half round tables.

DIMENSION KEY

W – width
 D – depth
 H – height of worksurface
 KW – kneehole width
 X & Y – dimensions as indicated on line drawing

Dimensions are in inches and approximate.
 Contact Customer Service if dimensions are critical.

KRUG EXPRESS

See page 346 for Krug Express program.

STANDARD FINISHES

For a complete list of standard finishes, please see page 347 for Standard Wood Finishes or In-Stock Laminates.

MODESTY PANELS

Modesty Panels are not available on half round tables.

VENEER TOPS

Please note when ordering wood veneer tables, these tables can only be ordered with a wood edge.

REVO | CORNER CONNECTING TOPS RECTANGULAR TABLES W/ FOLDING C & T BASES

Description	Model	Laminate W/ PVC Edge	Rift Oak, Cherry, Walnut, Maple	W	D	H	KW	Shipping Weight	Cubic Feet
90 Corner Tops	59TC242490	515	563	33.75	23.75	29.25	33.75	36	2.5
	59TC303090	545	598	42.75	29.75	29.25	42	44	5.5
	59TC363690	583	640	50.5	35.75	29.25	50.5	61	8

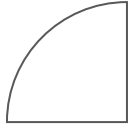

Description	Model	Laminate W/ PVC Edge	Rift Oak, Cherry, Walnut, Maple	W	D	H	KW	Shipping Weight	Cubic Feet
Rectangular Table w/ Folding C - Base. Casters or Glides - No Modesty Panel	59THRT6020CBFD_W_	1517	1899	59.75	19.75	29.25	48.5	69	5.5
	59THRT6620CBFD_W_	1605	1992	65.75	19.75	29.25	54.5	76	6
	59THRT7220CBFD_W_	1654	2051	71.75	19.75	29.25	60.5	82	6
	59THRT7820CBFD_W_	1805	2239	77.75	19.75	29.25	60.5	83	6.5
	59THRT8420CBFD_W_	1892	2313	83.75	19.75	29.25	48.5	84	7
	59THRT6024CBFD_W_	1567	1961	59.75	23.75	29.25	48.5	77	6
	59THRT6624CBFD_W_	1667	2060	65.75	23.75	29.25	54.5	80	6.5
	59THRT7224CBFD_W_	1727	2118	71.75	23.75	29.25	60.5	91	6.5
	59THRT7824CBFD_W_	1884	2310	77.75	23.75	29.25	60.5	92	7
	59THRT8424CBFD_W_	1969	2371	83.75	23.75	29.25	48.5	93	7.5
	59THRT6030CBFD_W_	1632	2036	59.75	29.75	29.25	48.5	88	6.5
	59THRT6630CBFD_W_	1729	2146	65.75	29.75	29.25	54.5	90	7
	59THRT7230CBFD_W_	1788	2214	71.75	29.75	29.25	60.5	104	7.5
	59THRT7830CBFD_W_	1956	2348	77.75	29.75	29.25	60.5	107	8
	59THRT8430CBFD_W_	2013	2427	83.75	29.75	29.25	48.5	109	8

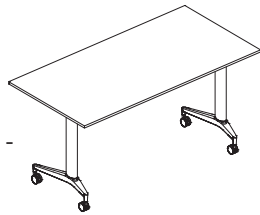

C-base inset from ends:
72" tables & smaller - 3"
78" tables - inset 6"
84" tables - inset 15"

Description	Model	Laminate W/ PVC Edge	Rift Oak, Cherry, Walnut, Maple	W	D	H	KW	Shipping Weight	Cubic Feet
Rectangular Table w/ Folding T- Base. Casters or Glides - No Modesty Panel	59THRT6024TBFD_W_	1567	1961	59.75	23.75	29.25	48.5	77	6
	59THRT6624TBFD_W_	1667	2060	65.75	23.75	29.25	54.5	80	6.5
	59THRT7224TBFD_W_	1727	2118	71.75	23.75	29.25	60.5	91	6.5
	59THRT7824TBFD_W_	1884	2310	77.75	23.75	29.25	60.5	92	7
	59THRT8424TBFD_W_	1969	2371	83.75	23.75	29.25	48.5	93	7.5
	59THRT6030TBFD_W_	1632	2036	59.75	29.75	29.25	48.5	88	6.5
	59THRT6630TBFD_W_	1729	2146	65.75	29.75	29.25	54.5	90	7
	59THRT7230TBFD_W_	1788	2214	71.75	29.75	29.25	60.5	104	7.5
	59THRT7830TBFD_W_	1956	2348	77.75	29.75	29.25	60.5	107	8
	59THRT8430TBFD_W_	2013	2427	83.75	29.75	29.25	48.5	109	8
	59THRT6036TBFD_W_	1768	2188	59.75	35.75	29.25	48.5	104	9
	59THRT6636TBFD_W_	1865	2301	65.75	35.75	29.25	54.5	113	9.5
	59THRT7236TBFD_W_	1923	2376	71.75	35.75	29.25	60.5	122	9.5
	59THRT7836TBFD_W_	2055	2474	77.75	35.75	29.25	60.5	126	10
	59THRT8436TBFD_W_	2114	2494	83.75	35.75	29.25	48.5	130	10

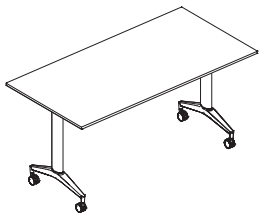

T-base inset from ends:
72" tables & smaller - 3"
78" tables - inset 6"
84" tables - inset 15"

ORDERING NOTES:

To order bases with glides, replace the 1st underscore in the model number with the letter "G";
e.g. "59THRT7224CBFDGW_".

To order bases with casters, replace the 1st underscore in the model number with the letter "C"; e.g. "59THRT7224CBFDCW_".

To order the standard cable manager replace the 2nd underscore in the model number with the number "1";

e.g. "59THRT7224CBFDGW1".

To order the high capacity base cable manager replace the 2nd underscore in the model number with the number "2";

e.g. "59THRT7224CBFDCW2".

DIMENSION KEY

W - width
D - depth
H - height of worksurface
KW - kneehole width
X & Y - dimensions as indicated on line drawing

Dimensions are in inches and approximate.
Contact Customer Service if dimensions are critical.

KRUG EXPRESS

See page 346 for Krug Express program.

STANDARD FINISHES

For a complete list of standard finishes, please see page 347 for Standard Wood Finishes or In-Stock Laminates.

MODESTY PANELS

Please see page 147 for options and upcharges.

VENEER TOPS

Please note when ordering wood veneer tables, these tables can only be ordered with a wood edge.

Description	Model	Table	Size	Upcharge	W	D	H	Shipping Weight	Cubic Feet
Fixed Modesty Panels Laminate No Cable Management Trough	F61	Rectangle	48"	305	46.5	4	10	14	2.5
			54"	313	52.5	4	10	15	2.5
			60"	320	58.5	4	10	16	3
			66"	331	64.5	4	10	17	3
			72"	339	70.5	4	10	18	3.5
			78"	357	76.5	4	10	20	3.5
		Arced Trapezoid	48" x 24"	263	22.5	4	10	9	1
			60" x 24"	278	34.5	4	10	12	1.5
			72" x 24"	305	46.5	4	10	14	2.5
			60" x 30"	272	28.5	4	10	11	1.5
Trapezoid	72" x 30"	296	40.5	4	10	13	2		
	60" x 36"	263	22.5	4	10	9	1		
	72" x 36"	278	34.5	4	10	12	1.5		
	48" x 24"	263	22.5	4	10	9	1		
			60" x 30"	272	28.5	4	10	11	1.5
			72" x 36"	278	34.5	4	10	12	1.5



ORDERING NOTES

On laminate modesty panels, the grain runs horizontally. To specify a fixed laminate modesty panel, apply above pricing for the specific modesty panel and add "F61" to the end of the tables model number; e.g. 59THRT7224CBFDGW1F61.

Fixed Modesty Panels Aluminum No Cable Management Trough	F51	Rectangle	48"	357	46.5	6	10	19	2.5
			54"	383	52.5	6	10	21	2.5
			60"	407	58.5	6	10	23	3
			66"	428	64.5	6	10	24	3
			72"	448	70.5	6	10	26	4
			78"	481	76.5	6	10	27	3.5
		Arced Trapezoid	48" x 24"	242	22.5	6	10	13	1.5
			60" x 24"	298	34.5	6	10	17	2
			72" x 24"	343	46.5	6	10	19	3
			60" x 30"	271	28.5	6	10	15	2
Trapezoid	72" x 30"	327	40.5	6	10	18	2.5		
	60" x 36"	242	22.5	6	10	13	1.5		
	72" x 36"	298	34.5	6	10	17	2		
	48" x 24"	242	22.5	6	10	13	1.5		
			60" x 30"	271	28.5	6	10	15	2
			72" x 36"	298	34.5	6	10	17	2

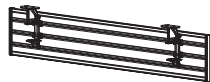
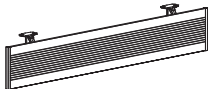

ORDERING NOTES

To specify an aluminum modesty panel, apply above pricing for the specific modesty panel and add "F51" to the end of the tables model number; e.g. 59THRT7224CBFDGW1F51.

DIMENSION KEY

Dimensions are in inches and approximate. Contact Customer Service if dimensions are critical.

STANDARD FINISHES

For a complete list of In-Stock Laminates, please see page 347.

KRUG EXPRESS

See page 346 for Krug Express program.

REVO | MODESTY PANELS

Description	Model	Table	Size	Upcharge	W	D	H	Shipping Weight	Cubic Feet
Fixed Modesty Panels Wood No Cable Management Trough	F11	Rectangle	48"	544	46.5	5	10	19	2.5
			54"	554	52.5	5	10	21	2.5
			60"	566	58.5	5	10	23	3
			66"	577	64.5	5	10	24	3
			72"	592	70.5	5	10	26	4
			78"	601	76.5	5	10	27	3.5
			84"	607	82.5	5	10	29	4.5
			Arced Trapezoid	48" x 24"	497	22.5	5	10	13
		60" x 24"		520	34.5	5	10	17	2
		72" x 24"		544	46.5	5	10	19	3
		60" x 30"		506	28.5	5	10	15	2
		72" x 30"		530	40.5	5	10	18	2.5
		60" x 36"		497	22.5	5	10	13	1.5
		72" x 36"		520	34.5	5	10	17	2
		Trapezoid	48" x 24"	497	22.5	5	10	13	1.5
60" x 30"	506		28.5	5	10	15	2		
72" x 36"	520		34.5	5	10	17	2		

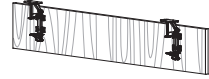
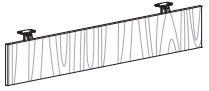

ORDERING NOTES

On wood modesty panels, the grain runs vertically. To specify a fixed wood modesty panel, apply above pricing for the specific modesty panel and add "F11" to the end of the tables model number; e.g. 59THRT7224CBFDGW1F11.

Fixed Modesty Panels Laminate With Cable Management Trough	F62	Rectangle	48"	339	46.5	5	10	19	2.5
			54"	347	52.5	5	10	15	2.5
			60"	354	58.5	5	10	23	3
			66"	364	64.5	5	10	17	3
			72"	375	70.5	5	10	26	4
			78"	396	76.5	5	10	20	3.5
			84"	419	82.5	5	10	29	4.5
			Arced Trapezoid	48" x 24"	298	22.5	5	10	13
		60" x 24"		314	34.5	5	10	17	2
		72" x 24"		339	46.5	5	10	19	3
		60" x 30"		306	28.5	5	10	15	2
		72" x 30"		331	40.5	5	10	18	2.5
		60" x 36"		298	22.5	5	10	13	1.5
		72" x 36"		314	34.5	5	10	17	2
		Trapezoid	48" x 24"	298	22.5	5	10	13	1.5
			60" x 30"	306	28.5	5	10	15	2
			72" x 36"	314	34.5	5	10	17	2



ORDERING NOTES

On laminate modesty panels, the grain runs horizontally. To specify a fixed laminate modesty panel, apply above pricing for the specific modesty panel and add "F62" to the end of the tables model number; e.g. 59THRT7224CBFDGW1F62.

DIMENSION KEY

Dimensions are in inches and approximate. Contact Customer Service if dimensions are critical.

STANDARD FINISHES

For a complete list of standard finishes, please see page 347 for Standard Wood Finishes or In-Stock Laminates.

KRUG EXPRESS

See page 346 for Krug Express program.

Description	Model	Table	Size	Upcharge	W	D	H	Shipping Weight	Cubic Feet		
Fixed Modesty Panels Aluminum With Cable Management Trough	F52	Rectangle	48"	404	46.5	4	10	14	2.5		
			54"	429	52.5	4	10	15	2.5		
			60"	456	58.5	4	10	16	3		
			66"	475	64.5	4	10	17	3		
			72"	494	70.5	4	10	18	3.5		
			78"	530	76.5	4	10	20	3.5		
			84"	570	82.5	4	10	21	4		
			Arced Trapezoid	48" x 24"	290	22.5	4	10	9	1	
		60" x 24"		349	34.5	4	10	12	1.5		
		72" x 24"		404	46.5	4	10	14	2.5		
		60" x 30"		321	28.5	4	10	11	1.5		
		72" x 30"		378	40.5	4	10	13	2		
		60" x 36"		290	22.5	4	10	9	1		
		Trapezoid	72" x 36"	349	34.5	4	10	12	1.5		
			48" x 24"	290	22.5	4	10	9	1		
			60" x 30"	321	28.5	4	10	11	1.5		
					72" x 36"	349	34.5	4	10	12	1.5

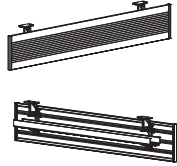

ORDERING NOTES

To specify an aluminum modesty panel, apply above pricing for the specific modesty panel and add "F52" to the end of the tables model number; e.g. 59THRT7224CBFDGW1F52.

Fixed Modesty Panels Wood with Cable Management Trough	F12	Rectangle	48"	574	46.5	6	10	19	2.5		
			54"	588	52.5	6	10	21	2.5		
			60"	601	58.5	6	10	23	3		
			66"	614	52.5	6	10	24	3		
			72"	628	70.5	6	10	26	4		
			78"	637	76.5	6	10	27	3.5		
			84"	645	82.5	6	10	29	4.5		
			Arced Trapezoid	48" x 24"	506	22.5	6	10	13	1.5	
		60" x 24"		541	34.5	6	10	17	2		
		72" x 24"		574	46.5	6	10	19	3		
		60" x 30"		522	28.5	6	10	15	2		
		72" x 30"		555	40.5	6	10	18	2.5		
		60" x 36"		506	22.5	6	10	13	1.5		
		Trapezoid	72" x 36"	541	34.5	6	10	17	2		
			48" x 24"	506	22.5	6	10	13	1.5		
			60" x 30"	522	28.5	6	10	15	2		
					72" x 36"	541	34.5	6	10	17	2

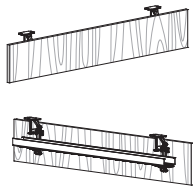

ORDERING NOTES

On wood modesty panels, the grain runs vertically. To specify a fixed wood modesty panel, apply above pricing for the specific modesty panel and add "F12" to the end of the tables model number; e.g. 59THRT7224CBFDGW1F12.

DIMENSION KEY

Dimensions are in inches and approximate. Contact Customer Service if dimensions are critical.

STANDARD FINISHES

For a complete list of standard wood finishes, please see page 347.

KRUG EXPRESS

See page 346 for Krug Express program.

REVO | MODESTY PANELS

Description	Model	Table	Size	Upcharge	W	D	H	Shipping Weight	Cubic Feet	
Fixed Modesty Panels Laminate For Power/ Data	F63	Rectangle	48"	432	46.5	5	10	19	2.5	
			54"	445	52.5	5	10	21	2.5	
			60"	450	58.5	5	10	23	3	
			66"	458	64.5	5	10	24	3	
			72"	470	70.5	5	10	26	4	
			78"	484	76.5	5	10	27	3.5	
			84"	503	82.5	5	10	29	4.5	
			Arced	48" x 24"	392	22.5	5	10	13	1.5
				Trapezoid	60" x 24"	408	34.5	5	10	17
		72" x 24"			432	46.5	5	10	19	3
		Trapezoid	60" x 30"	401	28.5	5	10	15	2	
			72" x 30"	425	40.5	5	10	18	2.5	
			60" x 36"	392	22.5	5	10	13	1.5	
			72" x 36"	408	34.5	5	10	17	2	
			Trapezoid	48" x 24"	392	22.5	5	10	13	1.5
		60" x 30"		401	28.5	5	10	15	2	
		72" x 36"		408	34.5	5	10	17	2	



ORDERING NOTES

On laminate modesty panels, the grain runs horizontally. To specify a fixed laminate modesty panel, apply above pricing for the specific modesty panel and add "F63" to the end of the tables model number; e.g. 59THRT7224CBFDGW1F63.

Fixed Modesty Panels Aluminum For Power/ Data	F53	Rectangle	48"	480	46.5	5	10	19	2.5	
			54"	505	52.5	5	10	21	2.5	
			60"	528	58.5	5	10	23	3	
			66"	559	64.5	5	10	24	3	
			72"	589	70.5	5	10	26	4	
			78"	632	76.5	5	10	20	3.5	
			84"	678	82.5	5	10	29	4.5	
			Arced	48" x 24"	370	22.5	5	10	13	1.5
				Trapezoid	60" x 24"	426	34.5	5	10	17
		72" x 24"			480	46.5	5	10	19	3
		Trapezoid	60" x 30"	397	28.5	5	10	15	2	
			72" x 30"	447	40.5	5	10	18	2.5	
			60" x 36"	370	22.5	5	10	13	1.5	
			72" x 36"	426	34.5	5	10	17	2	
			Trapezoid	48" x 24"	370	22.5	5	10	13	1.5
		60" x 30"		397	28.5	5	10	15	2	
		72" x 36"		426	34.5	5	10	17	2	

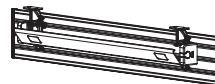
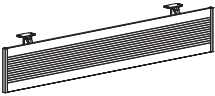

ORDERING NOTES

To specify an aluminum modesty panel, apply above pricing for the specific modesty panel and add "F53" to the end of the tables model number; e.g. 59THRT7224CBFDGW1F53.

DIMENSION KEY

Dimensions are in inches and approximate. Contact Customer Service if dimensions are critical.

STANDARD FINISHES

For a complete list of In-Stock Laminates, please see page 347.

KRUG EXPRESS

See page 346 for Krug Express program.

Description	Model	Table	Size	Upcharge	W	D	H	Shipping Weight	Cubic Feet	
Fixed Modesty Panels Wood For Power/ Data	F13	Rectangle	48"	669	46.5	4	10	14	2.5	
			54"	682	52.5	4	10	15	2.5	
			60"	697	58.5	4	10	16	3	
			66"	708	64.5	4	10	17	3	
			72"	721	70.5	4	10	18	3.5	
			78"	737	76.5	4	10	20	3.5	
			84"	753	82.5	4	10	21	4	
			Arced	48" x 24"	602	22.5	4	10	9	1
			Trapezoid	60" x 24"	632	34.5	4	10	12	1.5
		72" x 24"		669	46.5	4	10	14	2.5	
		60" x 30"		617	28.5	4	10	11	1.5	
		72" x 30"		649	40.5	4	10	13	2	
		60" x 36"		602	22.5	4	10	9	1	
		72" x 36"		632	34.5	4	10	12	1.5	
		Trapezoid	48" x 24"	602	22.5	4	10	9	1	
60" x 30"	617		28.5	4	10	11	1.5			
72" x 36"	632		34.5	4	10	12	1.5			

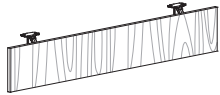

ORDERING NOTES

On wood modesty panels, the grain runs vertically. To specify a fixed wood modesty panel, apply above pricing for the specific modesty panel and add "F13" to the end of the tables model number; e.g. 59THRT7224CBFDGW1F13.

Flip Modesty Panels Laminate For Power/ Data	Y64	Rectangle	48"	480	46.5	6	10	19	2.5	
			54"	490	52.5	6	10	21	2.5	
			60"	497	58.5	6	10	23	3	
			66"	505	64.5	6	10	24	3	
			72"	516	70.5	6	10	26	4	
			78"	530	76.5	6	10	20	3.5	
			84"	549	82.5	6	10	29	4.5	
			Arced	48" x 24"	439	22.5	6	10	13	1.5
				Trapezoid	60" x 24"	454	34.5	6	10	17
		72" x 24"			480	46.5	6	10	19	3
		60" x 30"	448		28.5	6	10	15	2	
		72" x 30"	472		40.5	6	10	18	2.5	
		60" x 36"	439		22.5	6	10	13	1.5	
		72" x 36"	454		34.5	6	10	17	2	
		Trapezoid	48" x 24"	439	22.5	6	10	13	1.5	
60" x 30"	448		28.5	6	10	15	2			
72" x 36"	454		34.5	6	10	17	2			



ORDERING NOTES

On laminate modesty panels, the grain runs horizontally. To specify a flip laminate modesty panel, apply above pricing for the specific modesty panel and add "Y64" to the end of the tables model number; e.g. 59THRT7224CBFDGW1Y64.

DIMENSION KEY

Dimensions are in inches and approximate. Contact Customer Service if dimensions are critical.

STANDARD FINISHES

For a complete list of standard finishes, please see page 347 for Standard Wood Finishes In-Stock Laminates.

KRUG EXPRESS

See page 346 for Krug Express program.

REVO | MODESTY PANELS

Description	Model	Table	Size	Upcharge	W	D	H	Shipping Weight	Cubic Feet
Flip Modesty Panels Aluminum For Power/ Data	Y54	Rectangle	48"	528	46.5	6	10	19	2.5
			54"	554	52.5	6	10	21	2.5
			60"	576	58.5	6	10	23	3
			66"	608	64.5	6	10	24	3
			72"	640	70.5	6	10	26	4
			78"	687	76.5	6	10	27	3.5
			84"	736	82.5	6	10	29	4.5
			84"	736	82.5	6	10	29	4.5
		Arced Trapezoid	48" x 24"	419	22.5	6	10	13	1.5
			60" x 24"	476	34.5	6	10	17	2
			72" x 24"	528	46.5	6	10	19	3
			60" x 30"	448	28.5	6	10	15	2
			72" x 30"	494	40.5	6	10	18	2.5
			60" x 36"	419	22.5	6	10	13	1.5
			72" x 36"	476	34.5	6	10	17	2
Trapezoid	48" x 24"	419	22.5	6	10	13	1.5		
	60" x 30"	448	28.5	6	10	15	2		
	72" x 36"	476	34.5	6	10	17	2		

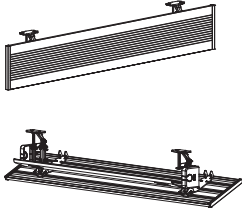

ORDERING NOTES

To specify a flip aluminum modesty panel, apply above pricing for the specific modesty panel and add "Y54" to the end of the tables model number; e.g. 59THRT7224CBFDGW1Y54.

Flip Modesty Panels Wood For Power/ Data	Y14	Rectangle	48"	710	46.5	6	10	19	2.5
			54"	723	52.5	6	10	21	2.5
			60"	736	58.5	6	10	23	3
			66"	748	64.5	6	10	24	3
			72"	760	70.5	6	10	26	4
			78"	777	76.5	6	10	27	3.5
			84"	793	82.5	6	10	29	4.5
			84"	793	82.5	6	10	29	4.5
		Arced Trapezoid	48" x 24"	647	22.5	6	10	13	1.5
			60" x 24"	679	34.5	6	10	17	2
			72" x 24"	710	46.5	6	10	19	3
			60" x 30"	663	28.5	6	10	15	2
			72" x 30"	697	40.5	6	10	18	2.5
			60" x 36"	647	22.5	6	10	13	1.5
			72" x 36"	679	34.5	6	10	17	2
Trapezoid	48" x 24"	647	22.5	6	10	13	1.5		
	60" x 30"	663	28.5	6	10	15	2		
	72" x 36"	679	34.5	6	10	17	2		

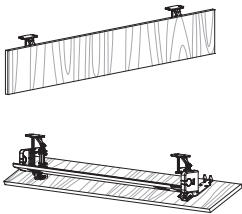

ORDERING NOTES

On wood modesty panels, the grain runs vertically. To specify a flip wood modesty panel, apply above pricing for the specific modesty panel and add "Y14" to the end of the tables model number; e.g. 59THRT7224CBFDGW1Y14.

DIMENSION KEY

Dimensions are in inches and approximate. Contact Customer Service if dimensions are critical.

STANDARD FINISHES

For a complete list of standard wood finishes please see page 347.

KRUG EXPRESS

See page 346 for Krug Express program.

POWERPORTS

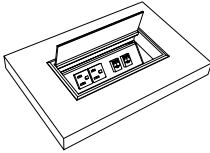
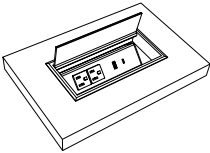
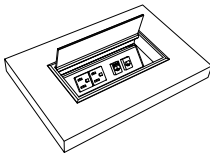
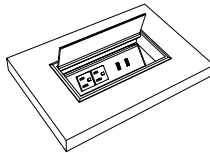
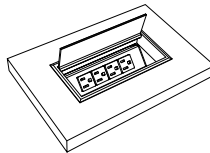
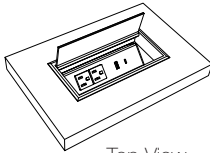
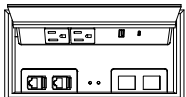
Description	Model	Price	W	D	H	Shipping Weight	Cubic Feet
PowerPort 1 - 2 RJ45s (Category 5/6)	PORT1	258	8	4	-	-	-
	Port Includes: 2 accessible power outlets & 1 side utility outlet powered by a 10' plug-in cord; 2 RJ45 (category 5/6) each with hard wired 10' data cords; 2 velcro wire managers and metal power port shroud. PortPort lid is Silver Metallic. NOTE: RJ45 jacks with hard wired data cords included here must be within 10' of building utilities source to be functional.						
PowerPort 2 - USB-A & USB-C	PORT2	260	8	4	-	-	-
	Port Includes: 2 accessible power outlets & 1 side utility outlet; 1 USB-A & 1 USB-C charging ports all powered by a 10' plug-in cord; 2 velcro wire managers and metal power port shroud. PortPort lid is Silver Metallic.						
PowerPort 3 - RJ11 & RJ45	PORT3	250	8	4	-	-	-
	Port Includes: 2 accessible power outlets & 1 side utility outlet; 1 RJ11 & 1 RJ45 (Category 5/6); 2 Velcro wire managers & PowerPort Shroud; 1 x 10 Foot Data Cords (T568A) & 1 x 14 Foot RJ11 (Telecomm); powered by a 10' plug-in cord. PortPort lid is Silver Metallic. NOTE: RJ45 & RJ11 jacks with hard wired data cords included here must be within 10' of building utilities source to be functional.						
PowerPort 4 - 2 USB-A	PORT4	265	8	4	-	-	-
	Port Includes: 2 accessible power outlets & 1 side utility outlet; 2- USB-A charging ports all powered by a 10' plug-in cord; 2 velcro wire managers and metal power port shroud. PortPort lid is Silver Metallic.						
PowerPort 5 - 4 Receptacles	PORT5	260	8	4	-	-	-
	Port Includes: 4 accessible power outlets & 1 side utility outlet powered by a 10' plug-in cord; 2 velcro wire managers and metal power port shroud. PortPort lid is Silver Metallic.						
PowerPort 6 - USB-A, USB-C & RJ45	PORT6	377	8	4	-	-	-
 	Port Includes: 2 accessible power outlets & 1 side utility outlet 1 USB-A, 1 USB-C charging ports all powered by a 10' plug-in power cord. Includes 2 velcro wire managers and metal power port shroud with 2 data plate knock outs, 1 #M02 plate insert & 2 #S01W RJ45 female input, punch down terminal output snap in jacks. 2nd data plate knock out is blank for future use.						

POWERPORTS

Description	Model	Price	W	D	H	Shipping Weight	Cubic Feet
Port - no Powerbar	Port0	127	8	4	-	-	-

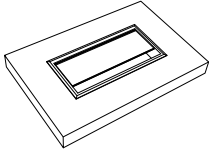

Port Includes: Port Cover & Bracket/Shroud only.

ORDERING NOTE: Velcro wire managers not included, see below for pricing. PortPort lid is Silver Metallic.

PowerPort Shroud with 2 Data Plate Knock-outs	SHROUD2KO	Must be requested - no upcharge	-	-	-	-	-
---	-----------	------------------------------------	---	---	---	---	---

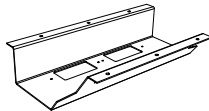

Angled PowerPort Shroud Includes: shroud with 2 data plate knock-outs in the bottom.

ORDERING NOTE: Please refer to data plate, data and AV integration options on page XX.

Velcro Wire Manager (qty 1)	WM-4	24	2	4.5	0.5	-	-
-----------------------------	------	----	---	-----	-----	---	---

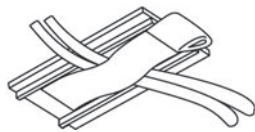

2 velcro wire managers are included with Ports 1-5.

Wire Management Trough	WM-72	169	72	3	1	-	-
------------------------	-------	-----	----	---	---	---	---



Wire Management Trough is standard in a 72" length & can be cut to specific length; double-sided tape installation.

4-Channel Wire Management	CM-72	214	72	3	1	-	-
---------------------------	-------	-----	----	---	---	---	---

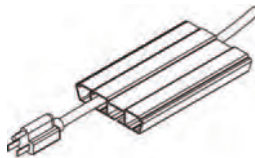



4-Channel Wire Management is standard in a 72" length & can be cut to specific length; double-sided tape installation.

Round Grommet	Round Grommet - Silver Metallic	142	-	-	-	-	-
	Round Grommet - Black	142	-	-	-	-	-

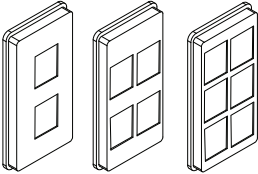

One 60mm Grommet in a standard position is available at no charge per table.

POWER/DATA

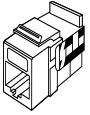
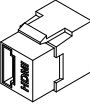
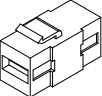
SNAP IN PORTS	Reference Code	Description	List Price
ADAPTOR PLATES			
	M02	Adaptor Plate (2) - accepts two snap in data ports	37
	M04	Adaptor Plate (4) - accepts four snap in data ports	37
	M06	Adaptor Plate (6) - accepts six snap in data ports	37
ORDERING NOTES: Blank covers are required when port is not in use, please see page 55.			
		RJ-45 - Category 6 data connection. This connector is also downwards compatible with Category 5 cabling. Connector is a female input with a #110 punch-down terminal block output (back side of Console interface) for on-site hard wire connection.	45
	S01W	RJ45-CAT6 (White)	
	S01B	RJ45-CAT6 (Blue)	
	S01R	RJ45-CAT6 (Red)	
		RJ11 - Telephone type connection. Connector is a female input with a #110 punch-down terminal block output (back side of Console interface) for on-site hard wire connection.	31
	S02W	RJ11 (White)	
	S02B	RJ11-B (Black)	
	S02G	RJ11-G (Green)	
	S02R	RJ11-R (Red)	
	S02Y	RJ11-Y (Yellow)	
	S04	HDMI - High Definition Multimedia Interface connection. Connector carries both HD audio and video data. Connector is a female-to-female pass through.	165
	S08	USB-A - Full size USB "A" style connection. Connector is a female-to-female pass through.	59

REVO | ELECTRICAL

Description	Model	Price	W	D	H	Shipping Weight	Cubic Feet
Power Entry - 4 wire, 2 circuit	59EC4PE	1282	-	-	-	1	.25

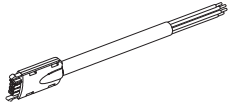

ORDERING NOTES

Please note when ordering the 4-wire Power Entry components, you must also order the 4-wire System, to work in conjunction. 4-wire Power Entry is hardwired into buildings power source.

Power Entry - 8 wire, 4 circuit	59EC8PE	182	-	-	-	1	.25
---------------------------------	---------	-----	---	---	---	---	-----

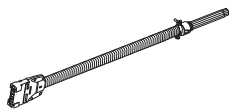

ORDERING NOTES

Please note when ordering the 8-wire Power Entry components, you must also order the 8-wire System, to work in conjunction. 8-wire Power Entry is hardwired into buildings power source.

4-wire 42" Jumper	59EC4JUMP-42	97	-	-	-	1	.25
-------------------	--------------	----	---	---	---	---	-----



ORDERING NOTES

This longer jumper cable is required when connecting one table off the edge to the end of another table using the 4-Trac® system. Jumper cables allow you to daisy chain each wired table to the next.

8-wire 42" Jumper	59EC8JUMP-42	150	-	-	-	1	.25
-------------------	--------------	-----	---	---	---	---	-----



ORDERING NOTES

This longer jumper cable is required when connecting one table off the edge to the end of another table using the 8-wire system. Jumper cables allow you to daisy chain each wired table to the next.

DIMENSION KEY

Dimensions are in inches and approximate. Contact Customer Service if dimensions are critical.

Description

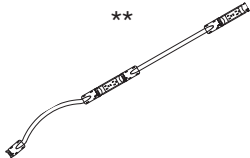
4-wire System	MODEL	MODEL	PRICE	W	D	H	SHIPPING	CUBIC
	<u>CIRCUIT 1</u>	<u>CIRCUIT 2</u>					WEIGHT	FEET
	59EC4-24-1	59EC4-24-2	204	-	-	-	2	.25
	59EC4-30-1	59EC4-30-2	208	-	-	-	2	.25
	59EC4-36-1	59EC4-36-2	211	-	-	-	2	.25
	59EC4-42-1	59EC4-42-2	213	-	-	-	2	.25
	59EC4-48-1	59EC4-48-2	216	-	-	-	2	.25
	59EC4-54-1	59EC4-54-2	223	-	-	-	2	.25
	59EC4-60-1	59EC4-60-2	227	-	-	-	2	.25
	59EC4-66-1	59EC4-66-2	233	-	-	-	2	.25
	59EC4-72-1	59EC4-72-2	239	-	-	-	2	.25
	59EC4-78-1	59EC4-78-2	243	-	-	-	2	.25
	59EC4-84-1	59EC4-84-2	248	-	-	-	2	.25

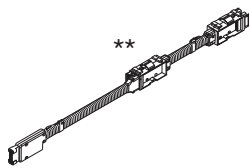
8-wire System	MODEL	MODEL	MODEL	MODEL	PRICE	W	D	H	SHIPPING	CUBIC
	<u>CIRCUIT 1</u>	<u>CIRCUIT 2</u>	<u>CIRCUIT 3</u>	<u>CIRCUIT 4</u>					WEIGHT	FEET
	59EC8-24-1	59EC8-24-2	59EC8-24-3	59EC8-24-4	295	-	-	-	2	.25
	59EC8-30-1	59EC8-30-2	59EC8-30-3	59EC8-30-4	316	-	-	-	2	.25
	59EC8-36-1	59EC8-36-2	59EC8-36-3	59EC8-36-4	346	-	-	-	2	.25
	59EC8-42-1	59EC8-42-2	59EC8-42-3	59EC8-42-4	353	-	-	-	2	.25
	59EC8-48-1	59EC8-48-2	59EC8-48-3	59EC8-48-4	361	-	-	-	2	.25
	59EC8-54-1	59EC8-54-2	59EC8-54-3	59EC8-54-4	369	-	-	-	2	.25
	59EC8-60-1	59EC8-60-2	59EC8-60-3	59EC8-60-4	382	-	-	-	2	.25
	59EC8-66-1	59EC8-66-2	59EC8-66-3	59EC8-66-4	389	-	-	-	2	.25
	59EC8-72-1	59EC8-72-2	59EC8-72-3	59EC8-72-4	397	-	-	-	2	.25
	59EC8-78-1	59EC8-78-2	59EC8-78-3	59EC8-78-4	405	-	-	-	2	.25
	59EC8-84-1	59EC8-84-2	59EC8-84-3	59EC8-84-4	412	-	-	-	2	.25

**** ORDERING NOTES**

Each model comes standard with an 18" Jumper. Please note when ordering the 4-wire or 8-wire System, you must also order the appropriate 4-wire or 8-wire Power Entry.

DIMENSION KEY

Dimensions are in inches and approximate. Contact Customer Service if dimensions are critical.

REVO | DATA MOUNTING BRACKET & ACCESSORIES

Description	Model	Suffix	Description	Price	W	D	H	Shipping Weight	Cubic Feet
Data Mount Bracket black	59DMB		Mounting bracket for configured plates and side mount ports	38	6	2.75	3.25	.5	.25

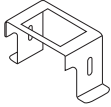

ORDERING NOTES

Opening on top is for mounting a Decora wall plate and adapter plate (wall plate and blank adapter plate are standard). Openings on sides are for mounting an optional DVI connector, and a VGA connector or Serial Port.

Configured Plate Options									
	HDMI	1 HDMI Pass thru	176	-	-	-	-	-	-
	2HDMI	2 HDMI Pass thru	264	-	-	-	-	-	-
	USB-A	1 USB-A Female Port	176	-	-	-	-	-	-
	2USB-A	2 USB-A Female Ports	264	-	-	-	-	-	-
	VGA3.5*	VGA/3.5 Mini Port	112	-	-	-	-	-	-
	XLR	1 STD XLR Female (Mic) Port	243	-	-	-	-	-	-
	2XLR	2 STD XLR Female (Mic) Ports	339	-	-	-	-	-	-

Side Mount Ports									
	DVI-D*	DVI-D to DVI-D	105	-	-	-	-	-	-
	DVI-I	DVI-I to DVI-I	170	-	-	-	-	-	-

ORDERING NOTES: To specify a Configured Plate Option apply above pricing and the corresponding suffix to the end of the Data Mount Bracket price and model number. e.g. 59DMBHDMI

Data Mount Bracket	59DMB2B	2 Blank Faceplate	60	-	-	-	-	-	-
Insert Plate & Face	59DMB4B	4 Blank Faceplate	75	-	-	-	-	-	-
Plates For Snap-in Ports	59DMB6B	6 Blank Faceplate	75	-	-	-	-	-	-

Snap-In Port Options									
1C	Blank Port Cover	(Qty 1)	16	-	-	-	-	-	-
2C	Blank Port Cover	(Qty 2)	22	-	-	-	-	-	-
4C	Blank Port Cover	(Qty 4)	38	-	-	-	-	-	-
1D	RJ45 - Cat 6	(Qty 1)	66	-	-	-	-	-	-
2D	RJ45 - Cat 6	(Qty 2)	126	-	-	-	-	-	-
4D	RJ45 - Cat 6	(Qty 4)	250	-	-	-	-	-	-
6D	RJ45 - Cat 6	(Qty 6)	369	-	-	-	-	-	-
1E	RJ11	(Qty 1)	27	-	-	-	-	-	-
2E	RJ11 x 2	(Qty 2)	43	-	-	-	-	-	-
4E	RJ11 x 4	(Qty 4)	66	-	-	-	-	-	-
1F	3.5 Mini Stereo		75	-	-	-	-	-	-
1G	USB "A" Female/Female		60	-	-	-	-	-	-
1H	USB Mini B Female - A Male Exit		258	-	-	-	-	-	-
1J	Fibre Optic Jack for MTRJ		60	-	-	-	-	-	-
1K	3 Pin Mini XLR (Mic) w/Cable		698	-	-	-	-	-	-
1L	HDMI Pass Thru		361	-	-	-	-	-	-
1M	White DSL Pass thru		38	-	-	-	-	-	-
1N	BNC		60	-	-	-	-	-	-
1O	RCA Black Strip (LT Audio)		60	-	-	-	-	-	-
1P	RCA Red Strip (RT Audio)		60	-	-	-	-	-	-
1Q	RCA Yellow Strip (Video)		60	-	-	-	-	-	-
1R	4 Pin Mini Din S-Video		112	-	-	-	-	-	-
1S	RJ45 - Cat 5	(Qty 1)	60	-	-	-	-	-	-
2S	RJ45 - Cat 5	(Qty 2)	118	-	-	-	-	-	-
1T	SRL/VGA Pass Thru		207	-	-	-	-	-	-

ORDERING NOTES: To specify a Mounting Bracket with Snap-In Port options, apply above pricing and the corresponding suffix to the end of the Data Mount Bracket & Snap-In Port Face Plate price and model number. e.g. 59DMB4B2D1E1G

DIMENSION KEY

Dimensions are in inches and approximate. Contact Customer Service if dimensions are critical.

REVO | CABLE MANAGEMENT, GANGING HARDWARE, TABLE STORAGE CART

Description	Model	Price	W	D	H	Shipping Weight	Cubic Feet
Surface Module	59SURFACEMODULE	185	8	4	-	-	-

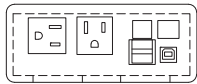

ORDERING NOTES

Surface module comes with 3 receptacles - 2 above the worksurface and 1 below, 2 USB ports, 1 USB printer port, 1 RJ45 and 1 RJ11. Surface Modules have a 10' cord. Folding tables cannot accommodate surface modules.

Power Bar	59PWR-USB	112	8	2	-	2	0.2
-----------	-----------	-----	---	---	---	---	-----



ORDERING NOTES

Power bar comes with 3 outlets and one powered USB port, and it has a 10' cord.

Table to Table Cable Manager -grey plastic	59CMB14	42	14	2	3	0.5	0.5
	59CMB17	51	17	2	3	0.5	0.5
	59CMB20	60	20	2	3	0.5	0.5
	59CMB26	76	26	2	3	0.5	0.5
	59CMB29	85	29	2	3	0.5	0.5
	59CMB38	111	38	2	3	0.5	0.5



59CMB14 - for use on connecting tables equal or less than 72"
 59CMB17 - for use on connecting 78" tables to tables equal or less than 72"
 59CMB20 - for use when connecting 78" tables to 78" tables
 59CMB26 - for use when connecting 84" tables to tables equal or less than 72"
 59CMB29 - for use when connecting 84" tables to 78" tables
 59CMB38 - for use when connecting 84" tables to 84" tables

Techflex F6 Split Braided Tube -black	59CMC18	55	18	1.5	1.5	0.5	0.5
--	---------	----	----	-----	-----	-----	-----



ORDERING NOTES

Flexible, semi-rigid wrap-able split braided tube. Used when running cables past corner connecting tops.

Ganging Brackets	59GANG	45	-	-	-	1	0.5
------------------	--------	----	---	---	---	---	-----

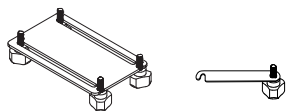
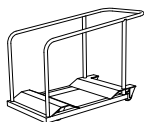

Table Storage Cart	59STC	958	60.5	32.5	34.5	82	2.5
--------------------	-------	-----	------	------	------	----	-----



ORDERING NOTES

Storage cart will hold 5 tables.

DIMENSION KEY

Dimensions are in inches and approximate.
 Contact Customer Service if dimensions are critical.

Terms and Conditions

Net 30 days on approved credit. A late payment charge of 1% per month will be applied on overdue invoices. This charge will be pro-rated to the number of days past 30 days that the invoice is overdue. All applicable sales taxes are extra. Distribution of this price list does not in itself constitute an offer to sell. Orders can be received only from authorized Krug dealers. Acceptance of any order and terms of sale may be established at the discretion of Krug. Deposits are required on orders received from new accounts as well as on large or special orders. Krug reserves the right to discontinue designs, or to change designs, construction, prices, or materials without notice.

Contact Information

Phone: 1.888.578.KRUG (5784) | Fax: 1.519.748.5177
Purchase Order Fax: 1.888.236.4783
Purchase Order E-mail: orders@krug.ca
Web: www.krug.ca E-mail: solutions@krug.ca

Customer Service Hours

Please note customer service hours are:
8:30 am to 5:00 pm est

Customer Satisfaction

It is the primary goal of Krug and our staff to ensure the complete satisfaction of our customers with our products and performance. If a problem arises with a Krug product after the expiration of the limited warranty period, Krug will exercise its best efforts to achieve the satisfaction of the customer in a manner that is fair to all concerned.

Order Acknowledgments

Each order will be acknowledged via e-mail or fax. This acknowledgment is the final agreement between Krug and the customer, superseding all previous communications regarding the purchase order. Where there is a discrepancy on a purchase order between a product code and a description, Krug will make every effort to resolve the discrepancy, but will be ruled by the product code ordered. Please check all acknowledgments for accuracy, and advise Krug of any discrepancies with a purchase order.

Order Cancellation

Krug reserves the right to not accept or allow cancellation of orders. All products are manufactured on a custom-made, make-to-order basis, and the purchasing, engineering and production of orders begins shortly after order placement - and the customer purchase order is a contract that authorizes Krug to manufacture the products. Acceptance of order cancellation (or partial cancellation) is solely at the discretion of Krug, and is dependent on the extent to which engineering, purchasing and manufacturing has been initiated by the time cancellation is requested. No order cancellations (partial or otherwise) are allowable more than 4 weeks from date of order placement (as order production is unable to be terminated by that point), and full payment of the acknowledged order value is required for any orders cancelled after 4 weeks. Cancellations may be allowable in less than 4 weeks after order placement, depending on the extent to which manufacturing has been initiated. An acceptance of order cancellation requires that the purchaser agrees to make payment for all costs incurred to the point of acceptance of cancellation. Cancellation charges include all costs for purchase of dedicated material and components, engineering costs for non-standard products, and all costs for manufacturing completed to that point, as well as a \$350 net charge for processing of the original order and for processing of cancellation invoicing.

Pricing

Krug endeavors to ensure that all prices in this price list reflect accurately our current prices. However, errors do occur and will be rectified through notices to the field. Krug reserves the right to acknowledge pricing that may be different from the price list.

Storage Charges

Krug reserves the right to assess a nominal storage charge if a customer does not accept shipment of an order within a week of the ship date.

Warranty

Krug warrants the construction and the finish of all our products to be free from defects in materials and workmanship for a period of 10 years from the date of purchase. This warranty is applicable to products in use by their original purchaser. This warranty does not apply to components not manufactured by Krug including textiles, which are subject to the specific warranties of those manufacturers, if any. Textiles (fabric, leather, vinyl, or any other covering material) suppliers do not guarantee their products for durability and color fastness, and nor does Krug. Casters, mechanical and electrical components have a warranty of five years from the date of purchase. The Krug warranty does not apply to COM-specified materials, damage caused by a carrier other than Krug, or variation in wood finishes due to natural wood color variation. Krug cannot be held responsible for variations in fabric dye lots from order to order. All fabric is carefully inspected when it is received, but a degree of variation in color should be expected. Repairs or replacement of any defect covered under this warranty by Krug will be made, at our option and method, at no charge to the original purchaser during the warranty period. Krug's judgement is final and binding with respect to the nature or cause of defects or damage, and the necessity or manner of repair or replacement.

This warranty does not apply to defects or damage resulting from:

- normal wear and tear occurring with the use of the product
- negligence, misuse, excessive use, alteration, improper cleaning or repair
- substitution or use of incorrect or unauthorized components or material
- handling or installation that is incorrect, or that causes damage or defect
- damage incurred by a freight carrier other than Krug
- wearing of finishes and fabrics, and normal variations in materials (including dye lot variations)
- properties of natural materials, including wood and leather
- exposure to environments with uncontrolled temperature and humidity (products must be transported, stored and used in climate-controlled conditions)

Export Packaging

Krug is pleased to provide the option for export packaging on all our products, to provide additional protection from damage. For shipments overseas, a quote for export packaging can be provided, based on the products to be ordered and the delivery destination - please contact Customer Service or Bids & Specification Support for more information and a quotation. KRUG is not responsible for shipment damage occurring on overseas shipments

Export Packaging is STRONGLY RECOMMENDED for:

- (A) all shipments outside of the lower 48 states and Canada.
- (B) all shipments that will be held in storage for an extended period prior to installation.

Important: Please note that Krug will not be responsible for damage claims on product shipped or stored in the above conditions but where export packaging has not been utilized.

Dimensions

Dimensions are in inches and approximate, and subject to change without notice. Contact Customer Service if dimensions are critical.

Installation Support

For assistance please contact Technical Support at 1-888-578-5784 x216 or e-mail installationhelp@krug.ca and you will be directed to the appropriate installation support person.

Custom Capabilities

Over 15% of our orders involve some type of custom work, and we invite our customers to make use of our extensive capabilities. These include:

- 1) Dimensional customization of standard size products
- 2) Custom wood finishes
- 3) For larger orders, completely custom-designed products, as well as non-standard wood species can be specified.

Custom orders may require additional production lead times. Contact Customer Service for more information.

GENERAL INFORMATION

Freight Terms and Conditions

1. All product is shipped FOB the Krug factory. Freight is either pre-paid to the destination or not pre-paid, depending on established customer specific freight terms.

2. Docks at the selected delivery location must be equipped to handle a 53' trailer. If a dock is inadequate for delivery by Krug, Krug will re-deliver to another local location and any additional costs will be charged to the customer.

3. For all deliveries, it is understood that Krug or its agent is making a dock delivery only (equipped to handle a 53' trailer), and any further work of truck unloading, delivery beyond the dock, installation, and removal of packaging is not authorized or paid for by Krug.

4. Drop shipments to the installation site, and timed deliveries, are available on larger shipments (full truckloads or slightly less) at no additional charge. Drop shipments or timed deliveries for smaller shipments may not be available, or if available will require a surcharge. Deliveries on an after hours basis, or on weekends, or any other special requirements, may be subject to a surcharge. Location and contact information, and the requested time of delivery, is required at least one week prior to the acknowledged shipment date. If this information is not provided one week in advance, or if the location or time of the drop shipment is changed less than one week in advance, a surcharge may be applied, and/or the drop shipment may not be scheduled. For deliveries requested Monday to Thursday after 5:00 pm, please apply a surcharge of \$250/shipment. For deliveries requested Monday to Friday before 7:00 am, please apply a surcharge of \$250/shipment. For deliveries requested Friday (after 3:00 pm) or weekends, please apply a surcharge of \$500/shipment. (local times).

5. For all deliveries - whether to the Customer location or drop shipment - any circumstances that result in the delay of our carrier (including unsuitable receiving facilities, or facilities not open or available), service charges will be applied at the rate of \$75/hour. Where re-delivery is necessary because of these circumstances, the full cost of re-delivery will be charged. If Less Than Truck Load is delivering, one hour is allocated to unload. Any additional time required to unload after the first hour is \$75/hour. If a Truck Load is delivering the order, three hours is allocated to unload. Any additional time required to unload is \$75/hour. Direct deliveries to site for large orders are possible, (must exceed \$60,000 net), and accommodate 48 - 53' trailers. Krug is responsible for delivery to the approved delivery address. If an address change is required, this must be authorized by Krug 5 business days prior to ship date. Any additional delivery costs incurred after this time will be charged to the customer.

Product Strength and Durability Testing

All Krug Conference products meet or exceed the testing requirements of ANSI/BIFMA X5.5-2014 or X5.9-2012.



Damaged Shipments

All Krug product is well engineered, carefully inspected, and expertly loaded onto our trucks at our Distribution Center. If you receive any damaged freight, we ask that you do not refuse the shipment. Krug is not responsible for damage to goods that occurs in transit or storage. It is the purchaser and/or receiver's responsibility to examine the goods upon receipt and to notify Krug of any damages, overages or shortages. Any discrepancies should be noted on the Bill of Lading. The delivering carrier will not accept responsibility for shortages or damages if signed "clear". Notification of concealed damage claims must be made to Krug Distribution within 5 days of delivery, along with digital pictures if available. All product and packaging must be available for inspection. Krug liability ceases after 5 business days and Krug will not be responsible for concealed damages if shipments are left unopened. Krug is not responsible for the condition of product that is stored or installed in an environment where temperature and humidity are not controlled.

Field Product Report Authorization

Krug's written authorization, in the form of an FPR number, must be obtained prior to incurring charges of any kind if Krug is expected to pay these charges. This includes authorization for returns, field repairs and replacements, post field repairs, installation and delivery charges. Krug reserves the right to have its representative inspect product related to any request for such authorizations, prior to that authorization being provided. Deductions from invoices paid for any charges to Krug, without prior written authorization in the form of an FPR, will not be accepted. Digital photographs may be required to complete the FPR process.

Care and Maintenance

Wood Finishes - Although Krug's extensive finishing process ensures a durable finish on all our products, there are several steps that can be taken to protect and prolong the life and beauty of the finish. Protect the top by placing felt pads on the bottom of any accessories and mechanical equipment. Rubber and oil will permanently mark surfaces. Use a desk pad to prevent possible damage and imprinting caused by writing instruments and sharp objects. Dust only with a clean, dry cloth, going with the grain. Clean any marks with a damp cloth, using a small quantity of mild soap or detergent. Do not use any wax-based polish, spray or silicone. Eventually, a film will build up and discolor the top. Do not place your furniture in a position of permanent exposure to direct sunlight.

Plastic Laminates - Clean plastic laminates with mild soap and warm water. Do not use steel wool, hot water, or any abrasive cleaning product.

Krug Panel Fabric Program

Tackboards can be upholstered in COM material supplied by the customer, and in a selection of stocked tackboard fabrics supplied by Momentum. The Momentum Panel fabrics are available on Krug Express. They are 100% polyester. For additional information and color selections, please refer to our Panel Fabrics card and Krug's website. www.krug.ca PRODUCTS / FABRICS / PANEL
The Momentum panel fabrics pass ASTM-E84-87 Fire Codes.
If memo samples are required please call Momentum at 1-800-366-6839.



PROGRAM DETAILS

KrugExpress orders are ready to ship by the date acknowledged. Delivery and shipping schedules may result in actual shipping of orders at a later date. Statutory holidays and scheduled factory vacations may add to acknowledged lead times of *KrugExpress* orders. Unless otherwise specified on the order, the customer's standard method of shipping Krug products will be utilized.

Available factory capacity for *KrugExpress* is filled by orders received on a "first come, first serve" basis. If the normal *KrugExpress* lead time is not available for your order because available capacity has been filled, you will be immediately advised of the earliest available ready-to-ship date. Please consult your Customer Service representative in advance if you wish to confirm the specific lead time availability for a *KrugExpress* order.

Orders must be received by midnight of a given day for that day to be considered the official day the order is received. Order lead times are acknowledged from the date the order is received, but not including the date the order is received.

KrugExpress orders must be "clean" when received in order to be considered officially received on a given day, and lead times will be acknowledged from the date orders are determined to be "clean".

Changes to *KrugExpress* orders are not allowed under any circumstances. Orders for product on *KrugExpress* must clearly state: "*KrugExpress*".

WOOD FINISHES AND LAMINATES

Standard Wood Finishes:

(See product pages for individual species availability)

SPECIES	FINISH
Cherry	Light Cherry
	Natural Cherry
	American Cherry
	Medium Cherry
	Standard Cherry
	Imperial Cherry
	Appalachian Cherry
	Sable Cherry
Maple	Clear Maple
	Honey Maple
	Wheat Maple
Oak	Light Oak
	SilverGrey on Oak
	Harvest Oak
	Mahogany Oak
	Medium Cherry on Oak
	Mellow Oak
	Walnut on Oak
Espresso on Oak	
Walnut	Natural Walnut
	Regular Walnut
	Mahogany on Walnut
	Dark Walnut
	Cordovan Walnut
	SilverGrey on Walnut
Anigre	Clear Anigre
	Medium Anigre
Palette	Black
	White
	Sand
	Soft Green
	Steel Blue
	Slate

NATURAL CHARACTERISTICS OF WOOD

Wood is a natural product with inherent color variations that will never be fully mitigated by the finishing process. Please anticipate variation in colors within a single unit, from piece to piece, and from Krug wood finish samples. If a very close match is required, a sample must be provided with the order and an upcharge will apply. Exact color matches are not possible.

CUSTOM WOOD FINISHES

Add 10% list to your order for special finishes, minimum upcharge is \$511 list per finish per order. (For example, on all orders up to \$5115 list, an upcharge of \$511 will apply, on orders \$5115 and up add 10% list to your order.) For orders with special finishes, a sample that is a minimum 3" by 3" must be received with the order. Special finishes may add additional lead time to production schedules. Since wood is a natural product, some variations in grain, color and stain acceptance will occur. In our finishing processes, we try to minimize variations, but some variation between samples and finished goods should be anticipated.

FINISH

Conference products feature Krug's finish, a proprietary catalyzed varnish formulation, that has repeatedly shown through independent laboratory testing to be the industry leader in durability and abrasion resistance. The Krug finish looks better longer than competitors and is uniquely suited to the demands of high traffic environments.

WOOD FINISHES TO MATCH STANDARD LAMINATES

Willow on Rift Oak
 Dune on Rift Oak
 Portobello on Rift Oak
 Ash on Rift Oak
 Copper on Cherry
 Shiraz Cherry
 Park Avenue Walnut
 Chocolate on Walnut
 Nutmeg on Walnut
 Dark Walnut
 Hardrock Maple

LAMINATES

Krug's in-stock Laminates are available in 17 different laminate selections. Please note that 4 of the colors (Gingerbread, Portobello, Ash and Willow) have textured finishes and may not be appropriate for use in patient areas due to infection control concerns. Minimum order quantities and extended lead times may apply for exotic laminate colors, please check with customer service. Polymer Edge will be selected to match the worksurface. Krug's previous laminate in-stock program will be phased out as in-stock supply depletes. Please contact customer service for availability.

IN-STOCK LAMINATES

Wood Grain Laminates	High Pressure Laminate Supplier	Textured Wood Grain Laminates	High Pressure Laminate Supplier
Champagne	Tafisa T492CR	Gingerbread	Tafisa T556UR
Hardrock Maple	Formica 86992-58	Portobello	Tafisa T557UR
Dune	Tafisa T491CR	Ash	Tafisa T535AT
Copper	Tafisa T521CR	Willow	Tafisa T543AT
Shiraz Cherry	Tafisa T472CR	Solid Laminates	
Park Avenue Walnut	Wilsonart 7984-38	Designer White	Wilsonart D354-60
Chocolate	Tafisa T498CR	Platinum	Tafisa T202CR
Nutmeg	Tafisa T477CR	Earth	Tafisa T767CR
Dark Walnut	Tafisa T469CR	Charcoal	Tafisa T228CR

PHASE OUT LAMINATES Almond - Black- Shadows - Edgewood Sycamore - Gunstock Walnut

NON-STOCKED LAMINATES

For specific lead time and application questions, please contact Krug Customer Service for your requirement. Upcharges will be applicable for non-stocked laminates, depending on their cost. Non-stock laminates may require a minimum order quantity, please contact customer service. Stocked polymer edges only can be specified for use with non-stocked laminates or tops will be self-edged.

SOLID SURFACE

SOLID SURFACE

The Solid Surface option provides an enhanced durability, protection and cleanability. It is available in 8 standard colors and is replaceable if it becomes damaged or degraded. See individual products for list upcharge chart.

GROUP GRADE A - WHITE

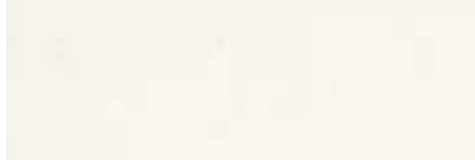

Glacier White

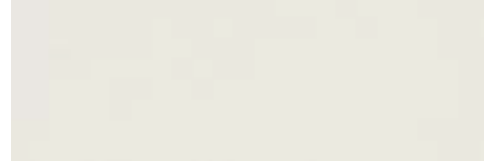

Cameo White

GROUP GRADE A - COLOR

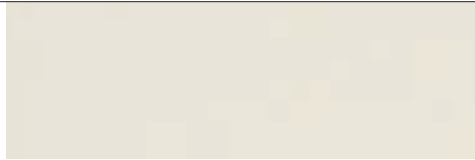

Bisque

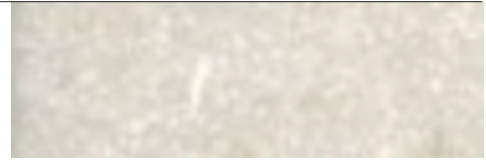

Linen

GROUP GRADE B



Antarctica

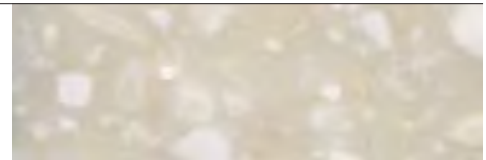

Savannah

GROUP GRADE C

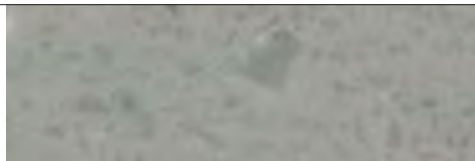

Dove

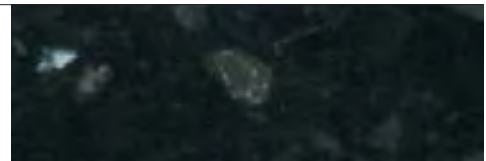

Deep Night Sky



www.fsc.org
FSC® C021699

The mark of responsible forestry



All products are air emissions certified and are available as FSC® certified

krug

solutions@krug.ca | www.krug.ca | 1.888.578.KRUG